

100% CE
MADE IN ITALY



ELEVAH[®]

a brand of *FARAONE*



www.elevah.com

FOR US, SAFETY IS NOT JUST A DETAIL

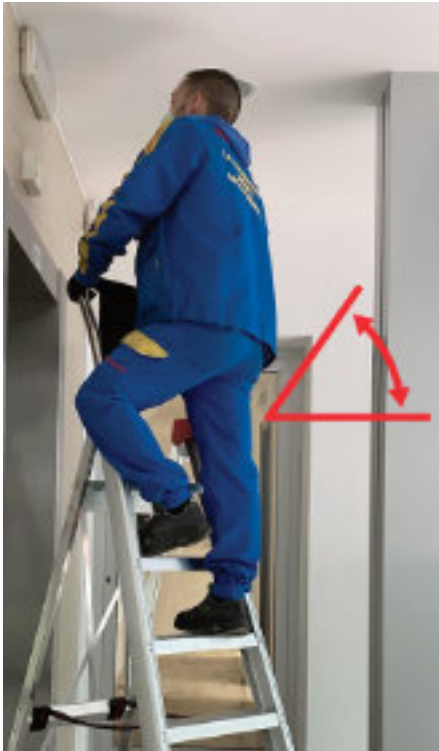

Maximize safety
in your company

The Elevah is characterized
by the great attention paid
to each detail to increase the
safety of the operator.

INCREASE THE PROTECTION FACTOR

By minimizing the risk of accidents when working at height.



PREVENTION IS BETTER THAN CURE

Raise the level of prevention

Thanks to ergonomically designed workstations, the risk of accidents is significantly reduced. These allow the user to work without excessive effort and maintain the correct posture.



SAVE TIME, EFFORT AND MONEY



Increase the profitability of your business

By having machines that can be moved quickly, are easy to handle and are equipped according to the activities carried out at height (maintenance, inspection or picking).





ZP150

ZP SERIE



ZP200



PKS920

PKS SERIE



PKS1200



ELEVAH 65
MOVE PICKING



MOVE

ELEVAH 65



ES MOVE



ELEVAH 75 TIRES



ELEVAH 70

6.5 m



ELEVVAH 65

MOVE

MOVE LIGHT

ES MOVE

TB

6 m



ELEVVAH 61

5 m



ELEVVAH 5

MOVE

INOX

MOVE LIGHT

B

ES MOVE

4 m



ELEVVAH 40

MOVE PICKING

B PICKING

T.FL

TIRES



ELEVVAH 65

MOVE PICKING



ELEVVAH 5

MOVE PICKING

T.FL

INOX

TIRES



ELEVVAH 40

MOVE

B



ELEVANH[®]

a brand of *Tarabome[®]*



EN280



MAINTENANCE SERIE

Everything at hand. Compact, ergonomic and easy-to-use solutions for inspection and maintenance work.

ELEVAH 40 MOVE

The evolution of ladders, ideal for facility management.

SELF-PROPELLED ON THE GROUND

- Maximum working height : 4 m
- Maximum platform height : 2 m
- Weight: 280 kg
- Maximum capacity : 200 kg
- Length: 100 cm
- Width: 71.5 cm
- Turning radius : 0
- Electronic control display



OPTIONAL
Customized color

Push around version Elevah 40B

ELEVAH E5 MOVE

The most compact platform

SELF-PROPELLED UP TO THE MAXIMUM HEIGHT

- Maximum working height : 5,15 m
- Maximum platform height : 3.15 m
- Maximum capacity : 200 kg (1 operator)
- Electronic tilt control system
- Length : 98 cm
- Width: 70 cm
- Turning radius : 0



EN280



200 kg



Maximum working height 5.15 m

ELEVAH E5 MOVE LIGHT

Easy to carry

SELF-PROPELLED UP TO THE MAXIMUM HEIGHT

- Maximum working height : 4.9 m
- Maximum platform height : 2.9 m
- Weight: 400 kg
- Maximum capacity : 200 kg
- Electronic tilt control system
- Length : 111 cm
- Width: 78 cm
- Turning radius : 0
- Additional work tray (OPTIONAL)



EN280



200 kg



Maximum working height 4.9 m



ELEVAH E5 ES MOVE



EN280



The compact platform with extendable basket

SELF-PROPELLED UP TO THE MAXIMUM HEIGHT

- Maximum working height : 4,9 m
- Maximum platform height : 2.9 m
- Maximum capacity : 150 kg (1 operator)
- Electronic tilt control system
- Length : 98 cm
- Width: 70 cm
- Turning radius : 0

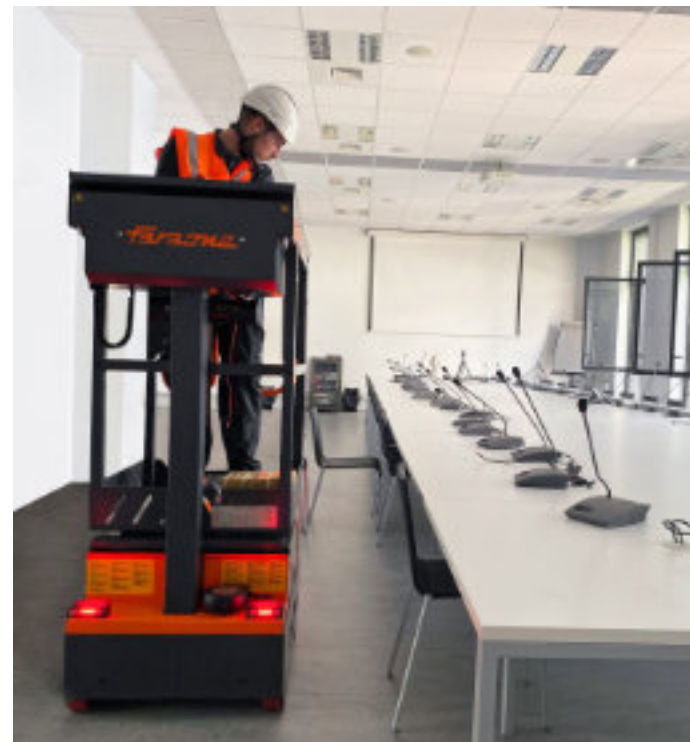

ELEVAN[®]

INOX

The stainless steel platform is ideal for all environments where hygiene and cleanliness are basic requirements, such as in the pharmaceutical and food industries.



TARAOME



ELEVAH 61

The first step to replace the ladder

PUSH AROUND



ELECTRICAL ADJUSTMENT



- Maximum working height with stabilizers: 6.1 m
- Maximum platform height with stabilizers: 4.8 m
- Max working height without stabilizers: 3.9 m
- Maximum platform height without stabilizers: 1.9 m
- Weight: 237 kg
- Maximum capacity: 200 kg (1 operator)
- Length with stabilizers: 129.7 cm
- Length without stabilizers: 118.7 cm



EN280



200 kg



Max working height 3.9 m (without stabilizers)



Maximum working height 6.1 m (with stabilizers)



ELEVAH 65-80 ES MOVE

Best ratio between machine size and accessibility

SELF-PROPELLED UP TO THE MAXIMUM HEIGHT

- Maximum working height (without extension): 7.7 m
- Maximum platform height : 5.7 m
- Maximum capacity (without extension): 200 kg
- Extension of the basket: 105 cm at max 6.8 m
- Electronic tilt control system
- Length : 153 cm
- Width: 78 cm
- Turning radius : 0
- Manual extension of the basket



Maximum working height 7.7 m

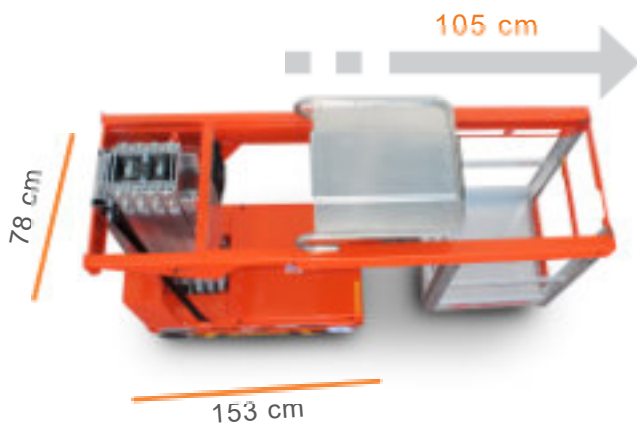

ELEVAH 65 TB

270°rotating basket

SELF-PROPELLED UP TO THE MAXIMUM HEIGHT

- Maximum working height (without extension): 6-5 m
- Maximum platform height : 4.5 m
- Maximum capacity : 120 kg
- 270° rotating basket up to 5.8 m working height
- Electronic tilt control system
- Length : 128 cm
- Width: 78 cm
- Turning radius : 0
- Manually rotating basket



EN280



200 kg

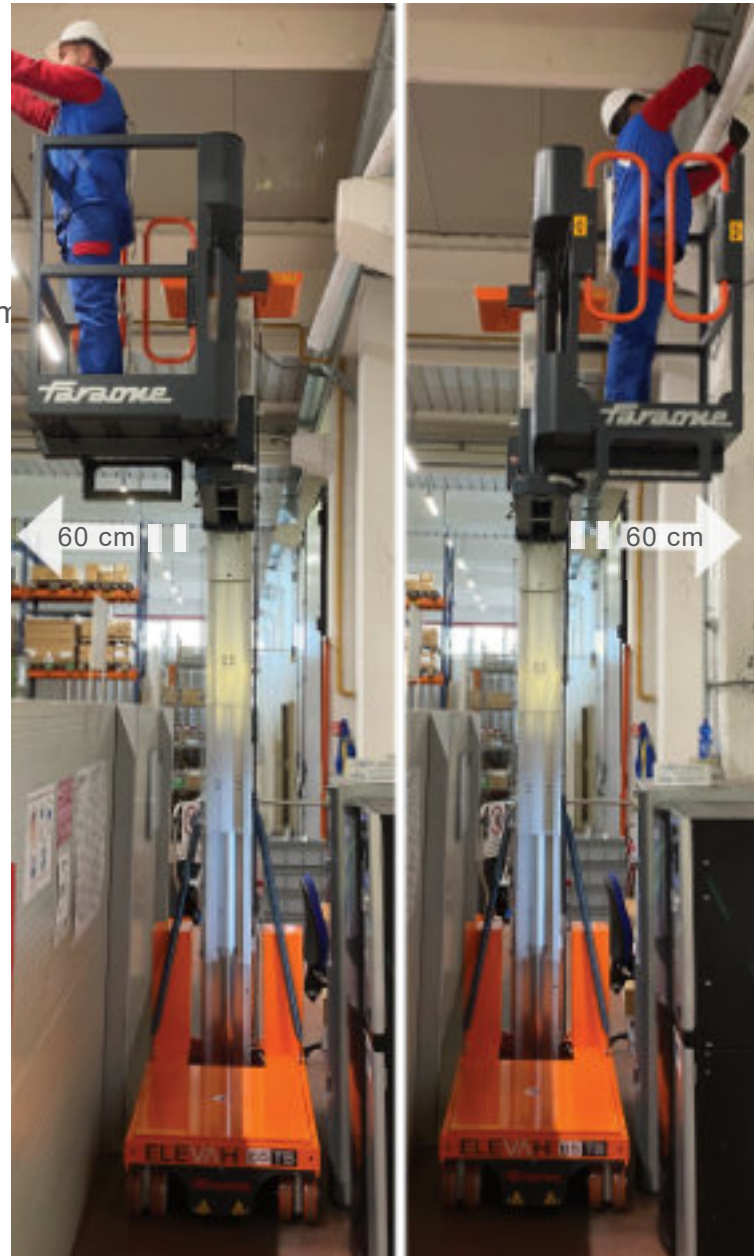

Maximum working height 6.5 m



ELEVAH 70

Easy to move, compact and safe!



EN280



200 kg



PUSH AROUND



ELECTRICAL ADJUSTMENT



- Maximum working height with stabilizers: 7.25 m
- Maximum platform height with stabilizers: 5.25 m
- Maximum working height without stabilizers: 6 m
- Maximum platform height without stabilizers: 4 m
- Weight: 430 kg
- Maximum capacity : 200 kg (1 operator)
- Length with stabilizers : 138 cm
- Length without stabilizers : 135 cm
- Width with stabilizers: 132 cm
- width without stabilizers : 78 cm

Maximum working height 7.25 m (with stabilizers)

Maximum working height 6.5 m (without stabilizers)

OPTIONAL

Customized color



ELEVAH 65-80 MOVE

For sensitive floors and with weight limits

SELF-PROPELLED UP TO THE MAXIMUM HEIGHT

- Maximum working height:
 - 65M: 6.5 m
 - 80M: 7.75 m
- Weight:
 - 65 Move Light: 538 kg
 - 80 Move: 750 kg
- Maximum capacity : 200 kg
- Electronic tilt control system
- Length : 128 cm
- Width: 78 cm
- Turning radius : 0
- Portable commands



EN280



200 kg



Maximum working height 7.75 m



ELEVAH 65 MOVE
LIGHT VERSION







EN3691-1



PICKING MACHINES

The widest range of material picking solutions.

Fast, ergonomic and above all safe storage from
4 m to 7.7 m working height!

ELEVAH 40 MOVE PICKING

The evolution of ladders

SELF-PROPELLED ON THE GROUND

- Maximum working height : 4 m
- Maximum platform height : 2 m
- Maximum capacity : 100kg + 100kg
- Platform size : 100 x 71.5 cm
- Turning radius : 0
- Foldable, electrically adjustable order picking tray



EN3691-1



200 kg



20

71.5 cm

100 cm



Maximum
platform
height 3 m

TARAONE

ELEVAH E5 MOVE PICKING

Ergonomic, compact and incredibly handy

SELF-PROPELLED UP TO THE MAXIMUM HEIGHT

- Maximum working height : 5.15 m
- Maximum platform height : 3.15 m
- Maximum capacity : 100 kg + 100 kg
- Moving and lifting at the same time
- Electronic tilt control system
- Platform size : 98 cm
 - Width: 70 cm
 - Turning radius : 0
- Foldable, electrically adjustable order picking tray

Maximum platform height 4.15 m

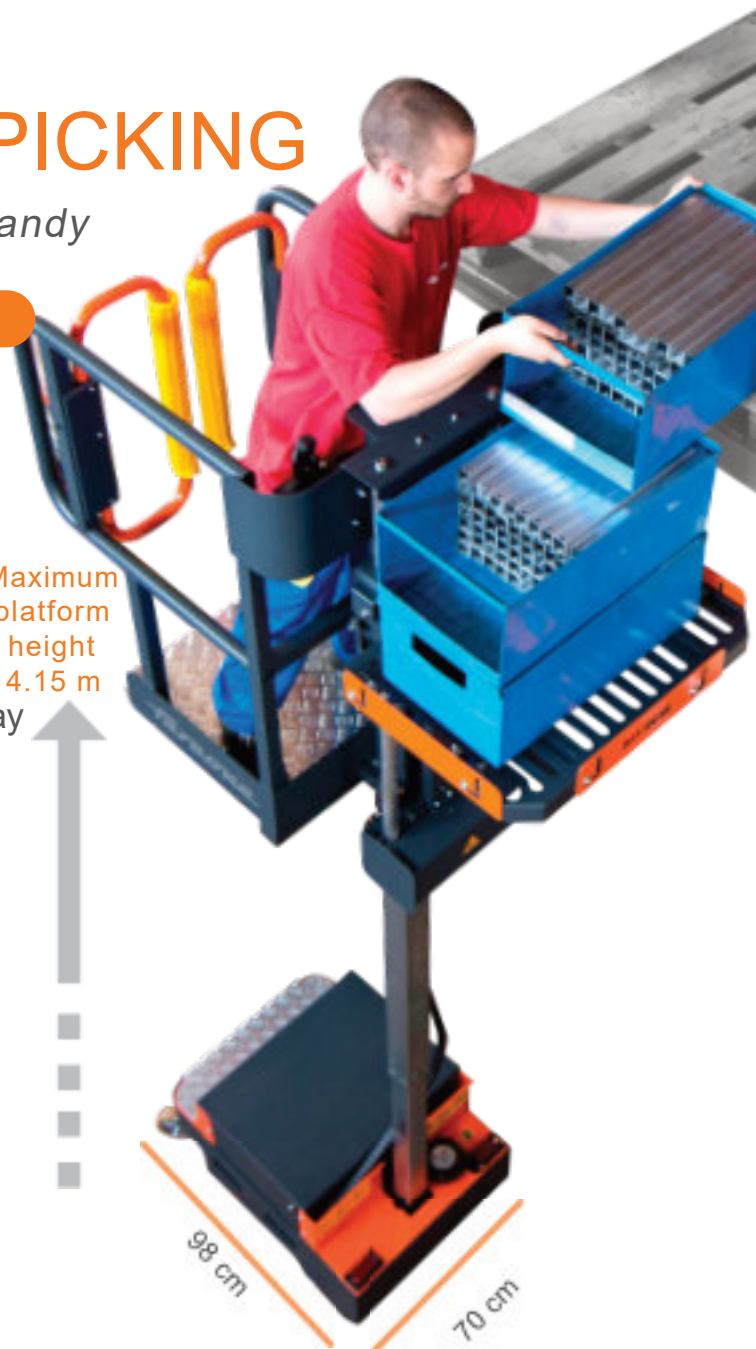

ELEVAH E5 T.FL

Picking machines to pick up the material from the ground

SELF-PROPELLED UP TO THE MAXIMUM HEIGHT

- Maximum working height : 5,15 m
- Maximum platform height : 3.15 m
- Maximum capacity : 100 kg + 120 kg
- Electronic tilt control system (E5 version)
 - Platform size: 189 cm
 - Width: 70 cm
 - Turning radius : 0
- Electrical height adjustment of the picking tray
- Picking tray provided with rollers



EN3691-1

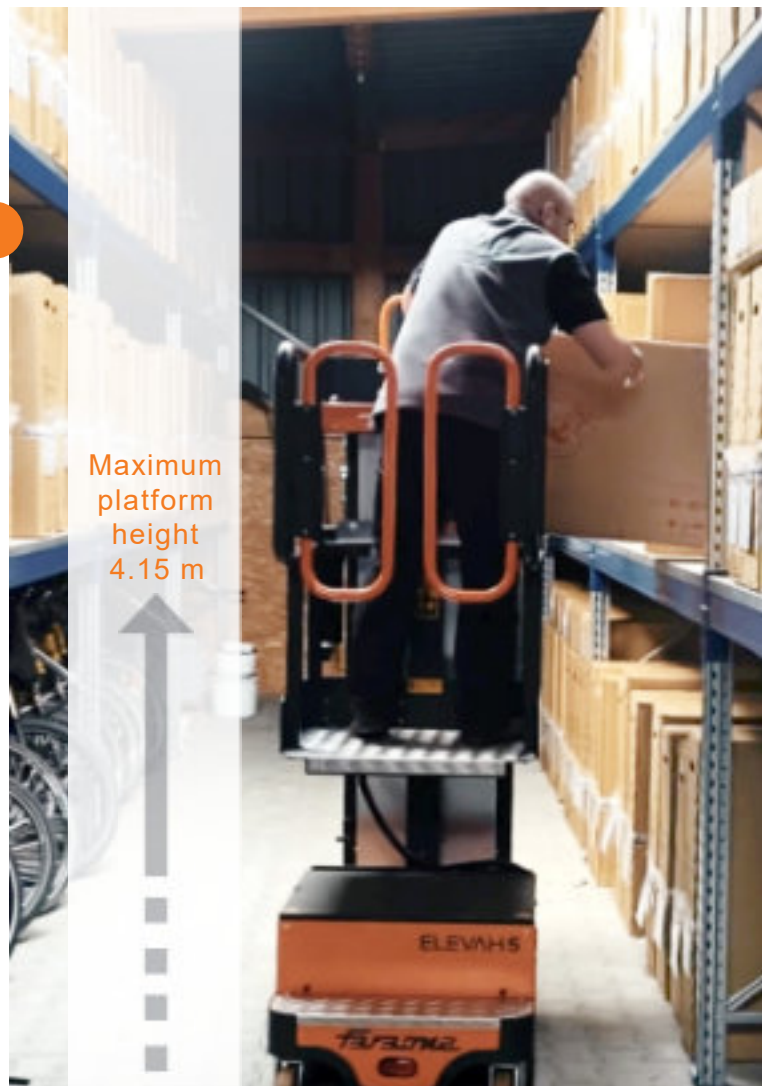

Maximum platform height 4.15 m



ELEVAH 40 T.FL VERSION

SELF-PROPELLED ON THE GROUND



ELEVAH 65 - 80 MOVE PICKING

Picking machines for high shelves

SELF-PROPELLED UP TO THE MAXIMUM HEIGHT

- Maximum working height :
 - 65MP: 6.50 m
 - 80MP: 7.70 m
- Maximum capacity : 100kg + 100kg
- Moving and lifting at the same time
- Electronic tilt control system
 - Platform size : 1280mm
 - Width: 780mm
 - Turning radius : 0
- Foldable, electrically adjustable order picking tray



EN3691-1

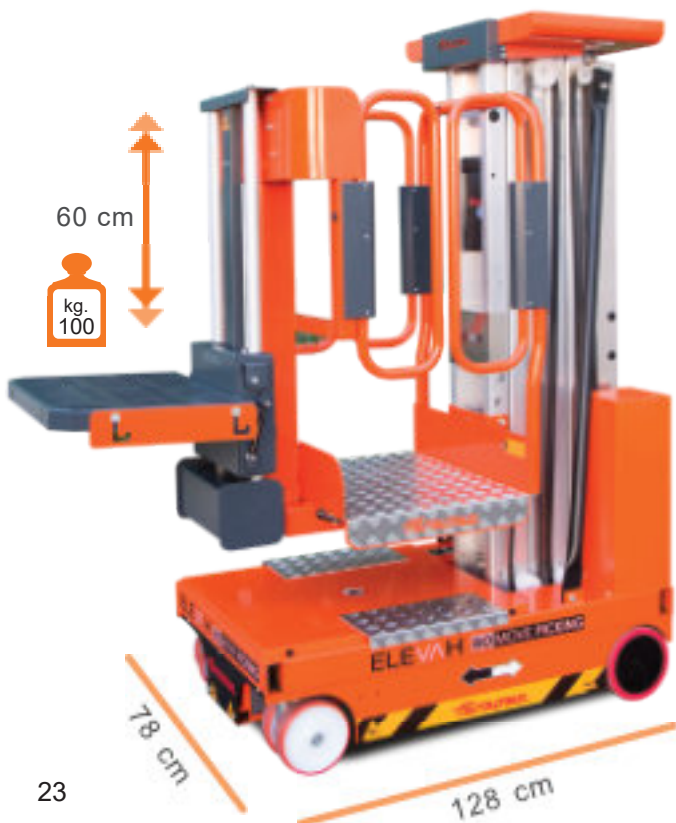

TARAONE

TIRES SERIES

The safest and most effective way to store tires.

Machines for lifting and storing a complete set of tires weighing up to 150 kg



ELEVAH 40 Tires

The evolution of the ladder for the tire industry

SELF-PROPELLED ON THE GROUND

- Max work height : 4 m
- Maximum platform height : 2 m
- Maximum capacity : 100 kg + 120 kg
- Platform size : 100 cm
- Width: 71,5 cm
- Turning radius : 0
- Electric loading system for a complete set of tires directly from the ground



EN3691-1



Maximum height with raised basket 3 m



71.5 cm

178 cm



ELEVAH E5 Tires

The practical, compact and indispensable machine for tire storage.

SELF-PROPELLED UP TO THE MAXIMUM HEIGHT

- Maximum working height : 5.15 m
- Maximum platform height : 3.15 m
- Maximum capacity : 100 kg + 120 kg
- Moving and lifting at the same time
- Electronic tilt control system
- Platform length : 172.5 cm
- Width: 70 cm
- Turning radius : 0
- Electric loading system for a complete set of tires directly from the ground



Maximum platform height 3.15 m



EN3691-1



220 kg

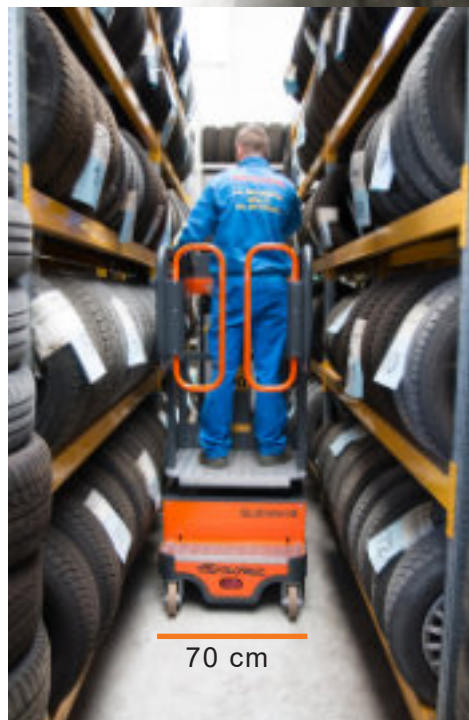

70 cm



kg. 120



172.5 cm

ELEVAH 75 Tires

Maximum efficiency and productivity, up to 6.3 m!

SELF-PROPELLED UP TO THE MAXIMUM HEIGHT

- Maximum working height : 7.6 m
- Maximum platform height : 5.7 m
- Maximum capacity : 100 kg + 150 kg
- Electronic tilt control system
- Moving and lifting at the same time
- Platform size : 208 cm
- Width: 78 cm
- Turning radius : 0
- Electric loading system for a complete set of tyres directly from the ground
- System that allows horizontal placement and effortless storage of tyres (optional)



EN3691-1



250 kg





Special machines for specific processes

Visit the section "special machines" on our website



Compact machine for the maintenance of Airbus engines



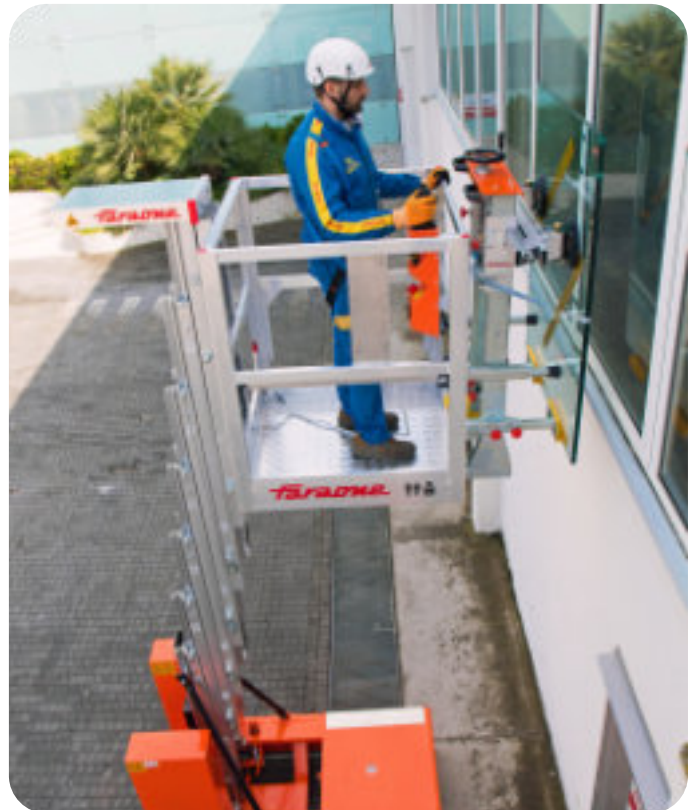

INCREASE SAFETY AND ERGONOMICS WITH ACCESSORIES

Picking machines



REDLIGHT1
Lateral signal lights



BLUESPOT
Frontal signal light



PEPP
Elements for the expansion of the picking tray



PMF
Element to lengthen the electric picking tray



E5CPT
Storage basket for picking tray, height 60 cm



SP.TFL
3 extractable protections for the picking platform



PFE.P
Frontal protection for electric picking tray



E5BLMA
Direction lock for castors



RL
Side rollers



Find all the accessories on elevah.com

Aerial platforms



E5ASP
Removable storage tray
cm 30x70 - Maximum
capacity 40 Kg



RADAR1
Frontal Anti-collision
Radar System



RADAR1B
Rear Anti-collision
Radar System



SCR
Loading system for ramps



BG
Batteries without maintenance
mod. 31 AGM 100 Ah (1 Kit)



LITHIUM BATTERIEN
Kit with 2 Trojan 12.8 Volt 110 A lithium
batteries + increased battery charger.



CA
Additional remote control for
loading on ramps



KEY ACC
Height limiter



AN-PR
Crushing
protection under
the basket



ELEVAH®

a brand of *faraone*®

Faraone Industrie S.p.A.
Via San Giovanni, 20
64018 Tortoreto (Teramo) Italia
Tel. +39 086177 221

faraone.com
elevah.com



Contact :

Małgorzata Mikrut
Manager ds. rozwoju rynku na terenie Polski

tel. +48 885 580 550
m.mikrut@faraone.pl

**FORMULARZ
KONTAKTOWY**

