



LIFTER

- | | |
|---|--|
| <input type="checkbox"/> HW02 | <input type="checkbox"/> HW02 EL |
| <input type="checkbox"/> HW03 | <input type="checkbox"/> HW03 EL |
| <input type="checkbox"/> HW BIG1 | <input type="checkbox"/> HW BIG1 EL |
| <input type="checkbox"/> HW BIG2 | <input type="checkbox"/> HW BIG2 EL |
| <input type="checkbox"/> HW BIG3 | <input type="checkbox"/> HW BIG3 EL |
| <input type="checkbox"/> HW BIG4 | <input type="checkbox"/> HW BIG4 EL |

USE AND MAINTENANCE INSTRUCTIONS

Translation of the original instructions



SECTION 1. INTRODUCTION

TABLE OF CONTENTS

SECTION 1. INTRODUCTION	1-1
TABLE OF CONTENTS	1-1
PREMISE	1-2
SYMBOLS AND TERMS	1-2
TECHNICAL SUPPORT - WARRANTY	1-3
NOTICES	1-3
SECTION 2. SAFETY PRECAUTIONS.....	2-1
GENERAL INFORMATION	2-1
PRELIMINARY PROCEDURES.....	2-1
SECTION 3. GENERAL TECHNICAL DATA	3-1
TECHNICAL SPECIFICATIONS / DIMENSIONS AND OVERALL DIMENSIONS - HW.....	3-1
TECHNICAL SPECIFICATIONS / DIMENSIONS AND OVERALL DIMENSIONS - HW EL	3-1
TECHNICAL SPECIFICATIONS / DIMENSIONS AND OVERALL DIMENSIONS - HW BIG.....	3-1
TECHNICAL SPECIFICATIONS / DIMENSIONS - HW BIG EL	3-1
HW / HW BIG LIFTER STABILISER OPERATING DIAGRAM	3-2
LOAD DIAGRAM HW / HW BIG.....	3-4
REFERENCES TO STANDARDS.....	3-5
SECTION 4. PREPARATION AND INSPECTION	4-1
GENERAL INFORMATION	4-1
PERSONNEL TRAINING.....	4-1
FULL INSPECTION BEFORE USE	4-2
FUNCTIONAL TEST	4-3
SAFETY WARNINGS FOR OPERATORS.....	4-3
WARNINGS FOR LOADING MODE	4-5
SECTION 5. LIFTER USE	5-1
INTRODUCTION.....	5-1
BATTERY CHARGE (electric version).....	5-1
LIFTER CONTROL CONSOLE (electric version).....	5-2
ASSEMBLING/DISMANTLING THE OUTRIGGERS (electric version)	5-3
ASSEMBLING/DISASSEMBLING THE OUTRIGGERS (manual version).....	5-4
USE OF THE LEVER ASSEMBLY	5-8
MOUNTING THE BALLAST KIT	5-9
LIFTING / LOWERING THE LOAD	5-10
MOVING THE LOAD.....	5-13
PARKING THE LIFTER	5-13
TRANSPORT AND LIFTING PROCEDURES.....	5-14
TRANSPORT IN COMPACT MODE (manual version)	5-15
REPORTING THE INCIDENT	5-15
SECTION 6. OPTIONAL.....	6-1
HW BALLAST KIT	6-1
PLANE WITH ROLLER CONVEYORS	6-1
SWING ARM.....	6-1
ADJUSTABLE FORKS.....	6-2
REEL PICK-UP PIPE	6-2
SPECIAL BASE	6-2
FORKS WITH ROLLER	6-3
SUCTION CUP KIT.....	6-3
SECTION 7. ROUTINE MAINTENANCE	7-1
MONTHLY MAINTENANCE.....	7-1
MAINTENANCE EVERY SIX MONTHS.....	7-2
MAINTENANCE EVERY TWO YEARS	7-3
MAINTENANCE EVERY FIVE YEARS.....	7-3
SECTION 8. MAINTENANCE INSTRUCTIONS	8-1
BATTERY MAINTENANCE (electric version)	8-1
REPLACE DRIVE TORQUE REDUCER OIL (electric version).....	8-1
LIFT BELT REPLACEMENT	8-2
SECTION 9. ATTACHED DOCUMENTATION	9-1
ANNEX 1 - Information on residual risks	9-1
ANNEX 2 - Circuit diagram (electrical version).....	9-4
ATTACHMENT 3 – FAC-SIMILE Declaration of conformity	9-5
SECTION 10. INSPECTION AND REPAIR LOG	7



ENGLISH

PREMISE

The purpose of this use and maintenance manual is to provide users with the essential information to carry out the procedures intended for safe and correct lifter operation, in accordance with the purposes it has been manufactured for.

All information in this manual must be read and understood before making any attempt to operate the lifter.

THIS MANUAL IS VERY IMPORTANT DOCUMENTATION; ALWAYS KEEP IT NEAR THE MACHINE.

Due to continuous improvements to the products, IMA Faraone Spa reserves the right to change the technical data without any prior notice. For updated information, contact Faraone Industrie Spa.



REMEMBER THAT NO EQUIPMENT IS SAFE IF THE OPERATOR DOES NOT COMPLY WITH THE SAFETY PRECAUTIONS



ANY CHANGES OR ALTERATIONS TO THE MACHINE MAY ONLY BE CARRIED OUT WITH THE MANUFACTURER'S PRIOR WRITTEN AUTHORISATION



SHOULD THE MACHINE BE SOLD TO A THIRD PARTY, ALL DOCUMENTATION MUST BE DELIVERED WITH IT

SYMBOLS AND TERMS



The danger symbol draws attention to potential hazards that might cause injuries. To prevent any injuries or fatal accidents, comply with all safety instructions associated with the symbol.



The information symbol is used to draw attention to useful information for understanding the operation of the machine and/or useful information for the operator



Arrows are used in the pictures of the machine to indicate the specific points described in the text of the manual.

Lifter: Machine designed to lift and move loads.

Loading forks: System to position the load being handled. They are made entirely from steel plate, shaped and welded.

Extensible structure: Structure connected to the frame that supports the loading forks and enables load lifting/lowering. It is built of extruded aluminium alloy profiles that slide on each other by sliding wheels. The kinematic connection between profiles is implemented by means of a lifting belt made of textile fibres.

Base frame: Lifter base. It is manufactured from shaped sheet metal (steel) profiles and components and then electro-welded and powder-coated. All the lifter components are installed on it.

Outriggers: They are made of electro-welded and then galvanised steel profiles; they are installed on the base frame and allow the hoist to maintain stable conditions while working and moving the machine.

TECHNICAL SUPPORT - WARRANTY



The Customer must make sure to have the serial number of the lifter and an accurate description of the problem or of the information to be provided before contacting the Manufacturer.

The warranty period is 12 months from the date of the purchase invoice.

Said warranty covers faulty components and the labour required for servicing, if this is carried out at the Manufacturer's premises (transport of the machine is charged to the purchaser).

The warranty is valid provided all rules laid down for correct use of the lifter are complied with. The lifter is designed and built to last for many years, provided that it is used for its intended purpose and that the inspections and maintenance described in this manual are carried out.

Faraone Industrie Spa deems it necessary to conduct an extensive analysis of all of the structural components every 10 (ten) years, to confirm their integrity.

NOTICES

For machines sold in Italy:

According to art. 71, paragraph 11 of the (Italian) Legislative Decree 81/2008, the employer/owner of the machine is obliged to report its commissioning to the local department of INAIL (National Institute for the Prevention of Accidents at Work).

In addition, he must subject the machine to periodic inspections to verify its actual state of preservation and efficiency, every two years (SEE: material lifting equipment, not hand-operated, with a load capacity of more than 200 kg, with a year of manufacture not older than 10 years).

For machines sold in other countries:

The owner /user of the machine must ascertain whether installation of the machine needs to be reported and/or any need for periodic inspections by specific competent agencies.

SECTION 2. SAFETY PRECAUTIONS

GENERAL INFORMATION

This section illustrates the necessary precautions for correct and safe use of the lifter and its maintenance. To guarantee safe operation of the lifter, it is necessary for a skilled person to establish a maintenance schedule based on the information provided in this manual, which must be strictly complied with.

The owner/user/operator/company granting the machine in leasing/the person receiving the lifter in leasing, must not accept responsibility of its operation before having carefully read the manual and completed training and the operating procedures, guided by an experienced and skilled operator.

For further information relating to safety, training, inspection, maintenance, application and operation, contact Faraone Industrie Spa.



FAILURE TO COMPLY WITH THE SAFETY PRECAUTIONS LISTED IN THE MANUAL MAY DAMAGE THE LIFTER AND PROPERTY AND CAUSE INJURIES OR FATAL ACCIDENTS.

PRELIMINARY PROCEDURES

Operator training and knowledge

- Carefully read the manual before using the lifter.



- Only use the lifter after being fully trained by authorised personnel.
- The lifter can only be used by authorised and skilled personnel.
- Read carefully and comply with all the ATTENTION statements and the operational instructions reported on the lifter and in the manual.
- Use the lifter for applications falling within those intended by Faraone Industrie Spa.
- All operational personnel must familiarise with the controls and operation of the lifter, as specified in the manual.
- Carefully read and comply with all company, local and government regulations in force, relating to lifter operation.

Inspection of the workplace

- Before using the lifter, the operator must take the necessary precautions to avoid any hazard in the work place.
- Do not operate the lifter on lorries, trailers, railway carriages, boats in water, scaffolding or similar, unless Faraone Industrie Spa has approved the operation in writing.

- The lifter can be started up at temperatures between -15°C and 40°C. Contact Faraone Industrie Spa for machine operation at temperatures not within the indicated range.

Lifter inspection

- Use the lifter only after having carried out the inspections and functional checks. For further instructions, refer to *Section 2* of this manual.
- Operate the lifter only after having carried out all assistance and maintenance set out in the requirements specified in this manual.
- Make sure all safety devices work properly. Any changes to such devices constitute a breach of the safety regulations.
- Do not operate the lifter if its signs or decals indicating the safety regulations or instructions are illegible or missing.

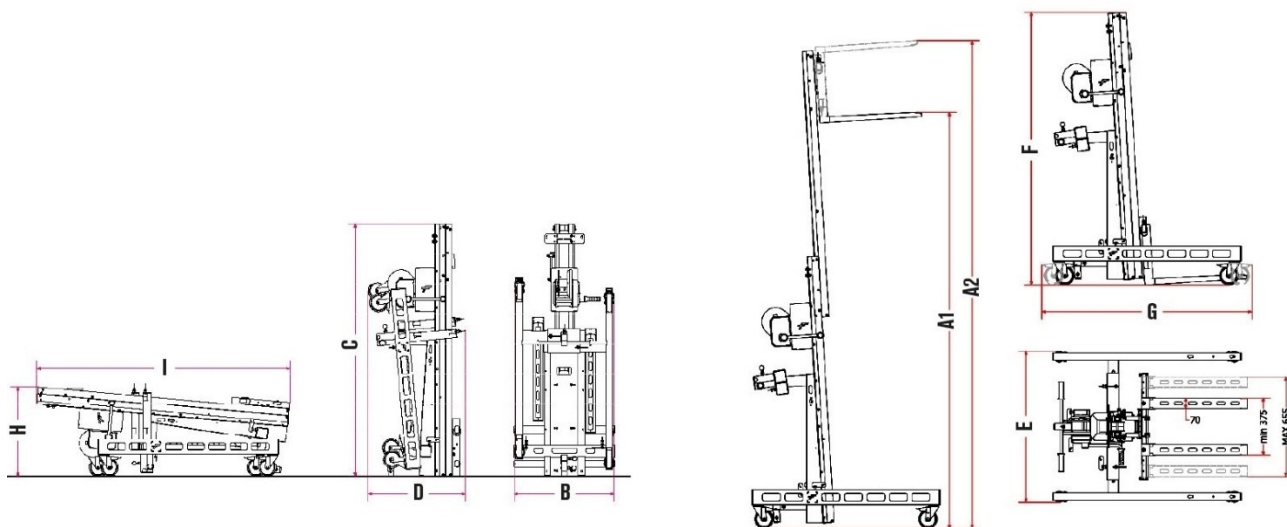


ANY CHANGES OR ALTERATIONS TO THE LIFTER MAY ONLY BE CARRIED OUT WITH PRIOR WRITTEN AUTHORISATION OF THE MANUFACTURER.



THE HW / HW BIG LIFTER IS A MACHINE DESIGNED EXCLUSIVELY TO LIFT AND TRANSPORT LOADS AND IS CONTROLLED BY AN OPERATOR ON FOOT.
THE LIFTER IS DESIGNED TO CIRCULATE ON SMOOTH, HORIZONTAL LAID SURFACES.
THE LIFTER MUST ONLY BE USED FOR THE PURPOSE IT WAS DESIGNED FOR.
ANY OTHER USE IS CONSIDERED MISUSE.

SECTION 3. GENERAL TECHNICAL DATA



TECHNICAL SPECIFICATIONS / DIMENSIONS AND OVERALL DIMENSIONS - HW

ART.	WEIGHT (kg)	CAPACITY (kg)	A1 MAX (cm)	A2 MAX (cm)	B (cm)	C (cm)	D (cm)	E (cm)	F (cm)	T (cm)	H (cm)	I (cm)	BALLASTS
HW02	92	250	265	310	78	176	70	100	180	138	62	176	1+1
HW03	100	200	400	445	78	176	70	100	180	142	67	176	2+2

TECHNICAL SPECIFICATIONS / DIMENSIONS AND OVERALL DIMENSIONS - HW EL

ART.	WEIGHT (kg)	CAPACITY (kg)	A1 MAX (cm)	A2 MAX (cm)	E (cm)	F (cm)	T (cm)	BALLASTS
HW02EL	142	250	265	310	100	180	138	1+1
HW03EL	150	200	400	445	100	180	142	2+2

TECHNICAL SPECIFICATIONS / DIMENSIONS AND OVERALL DIMENSIONS - HW BIG

ART.	WEIGHT (kg)	CAPACITY (kg)	A1 MAX (cm)	A2 MAX (cm)	B (cm)	C (cm)	D (cm)	E (cm)	F (cm)	T (cm)	H (cm)	I (cm)	BALLASTS
HWBIG1	95	300	150	195	70	194	70	100	197	135	62	194	1+1
HWBIG2	112	300	300	345	70	194	70	100	197	141	67	194	2+2
HWBIG3	144	250	450	495	70	199	74	133	192	182	-	-	2+2
HWBIG4	162	150	600	645	70	199	80	133	198	182	-	-	2+2

TECHNICAL SPECIFICATIONS / DIMENSIONS - HW BIG EL

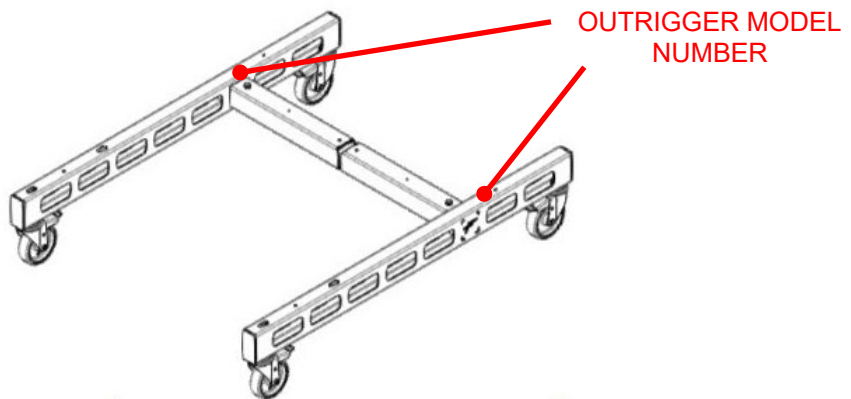
ART.	WEIGHT (kg)	CAPACITY (kg)	A1 MAX (cm)	A2 MAX (cm)	E (cm)	F (cm)	T (cm)	BALLASTS
HWBIG1EL	145	300	150	195	100	197	135	1+1
HWBIG2EL	162	300	300	345	100	197	141	1+1
HWBIG3EL	184	250	450	495	133	192	182	2+2
HWBIG4EL	204	150	600	645	133	198	182	2+2

HW / HW BIG LIFTER STABILISER OPERATING DIAGRAM

MODEL	MAX LOAD (kg)	STABILISATION	NUM. BALLASTS (with rear outrigger)	OUTRIGGER MODEL NUMBER	
HW02	250	Standard front / Rear / Lowered front	1 RH + 1 LH	1	
HW02 EL					
HW03	200		2 RH + 2 LH		
HW03 EL					
HW BIG 1	300		1 RH + 1 LH		2
HW BIG 1 EL					
HW BIG 2			2 RH + 2 LH		
HW BIG 2 EL					
HW BIG 3	250	Standard Front/Rear	1 RH + 1 LH		
HW BIG 3 EL					
HW BIG 4	150	Standard Front/Rear	2 RH + 2 LH		
HW BIG 4 EL					

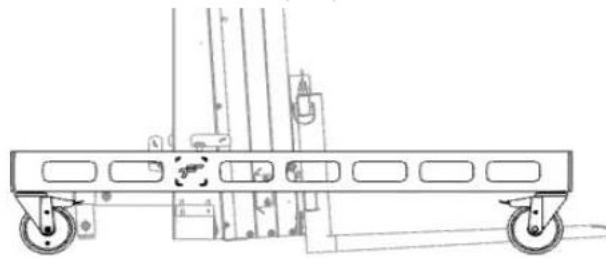


DANGER OF LIFTER TIPPING → IN ORDER TO IDENTIFY THE CORRECT STABILISER TO USE FOR THE LIFTER MODEL YOU ARE USING, EACH STABILISER IS MARKED WITH A NUMBER. REFER TO THE TABLE ABOVE FOR THE CORRECT OUTRIGGER/MODEL ASSOCIATION (THE NUMBER IS LOCATED ON THE TOP OF THE OUTRIGGER IN THE MARKED AREA AS SHOWN IN THE FIGURE BELOW).

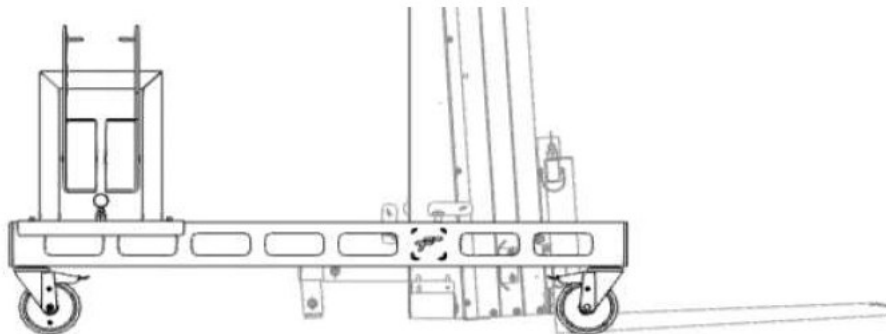


FOR POSSIBLE REPLACEMENT OF OUTRIGGERS, PLEASE REFER TO THE USE OF THE 'LEVER ASSEMBLY' IN THE SPECIFIC PARAGRAPH.

LIFTER WITH STANDARD FRONT STABILISATION

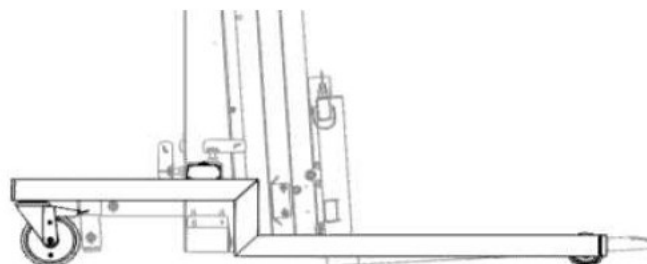


LIFTER WITH REAR STABILISATION



DANGER OF THE LIFTER TIPPING OVER → WHEN USING THE LIFTER WITH REAR STABILISATION, AFTER ASSEMBLING THE OUTRIGGERS, IT IS MANDATORY TO MOUNT THE BALLASTS. IT IS STRICTLY FORBIDDEN TO USE THE LIFTER WITHOUT THE REQUIRED NUMBER OF BALLAST WEIGHTS PER OUTRIGGER BEING ASSEMBLED.

LIFTER WITH LOW FRONT STABILISATION

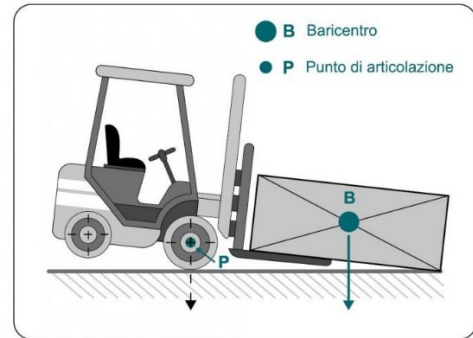
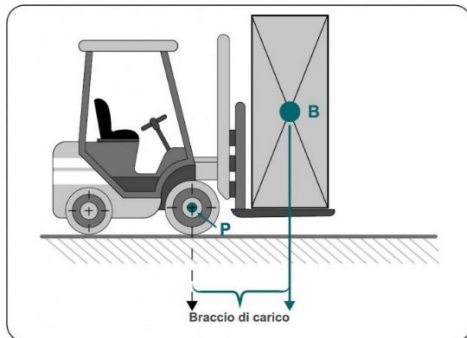


LOAD DIAGRAM HW / HW BIG

If a load of uniform weight is to be moved with the hoist, the centre of gravity (S) is in the middle, provided the load to be moved is cubic or cylindrical in shape; this makes it very easy to calculate the centre of gravity of the load, since it is always half the length of the load to be moved.

The maximum lifter capacity is only obtained at the centre of the loading forks.

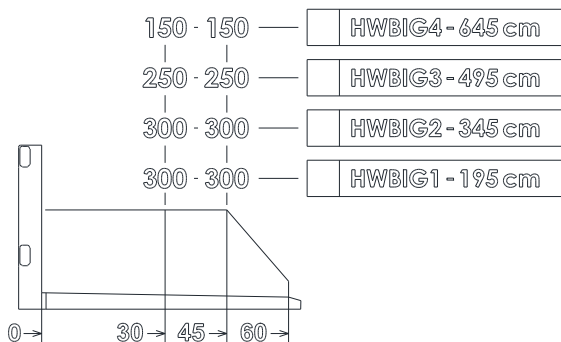
If it is necessary to increase the distance from the centre of gravity, the effective load capacity of the lifter is automatically reduced (such situations can occur, for example, due to an unfavourable position of the pallet to be loaded, even if the pallet load remains the same); in cases like this, the lifter could tip over even if the same loads had previously been handled without problems:



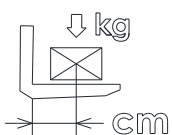
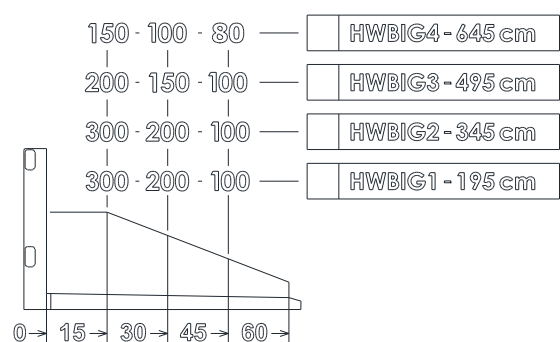
In the case of irregular loads, it is essential that the heaviest part is always picked up towards the back of the forks. In this way, the load centre distance will be minimised. Furthermore, it must be ensured that the load always rests directly on the back of the fork before transport.

The following is the load diagram of the lifter according to the type of stabiliser fitted:

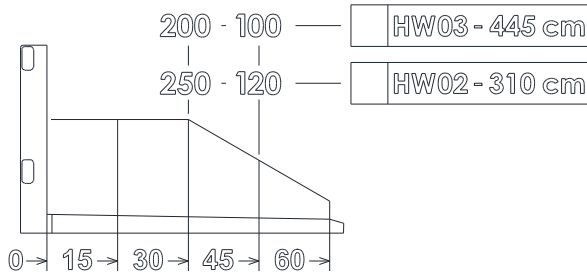
STANDARD / LOW FRONT OUTRIGGER



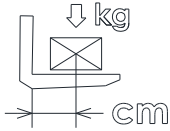
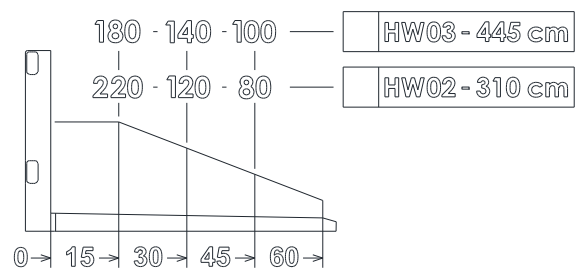
REAR OUTRIGGER



STANDARD / LOW FRONT OUTRIGGER



REAR OUTRIGGER



WHEN READING A FLOW RATE DIAGRAM, ALWAYS BEAR IN MIND THAT THE INFORMATION IS ONLY VALID FOR USE UNDER NORMAL LOAD CONDITIONS: UNEVEN FLOORS, UNEVENLY LOADED PALLETS OR MOVEMENT OF THE LOAD ALREADY LIFTED HAVE A SIGNIFICANT EFFECT ON THE LOAD CAPACITY AND TRANSPORT SAFETY OF A MATERIAL HOIST. SO THE FLOW RATE MUST BE CALCULATED INDIVIDUALLY FOR THESE EXCEPTIONAL SITUATIONS.

REFERENCES TO STANDARDS



THE MACHINE IS DESIGNED TO CIRCULATE INDOORS ON PREPARED SMOOTH HORIZONTAL SURFACES.
THE MACHINE MUST BE USED ONLY FOR ITS INTENDED PURPOSES.
ANY OTHER USE IS CONSIDERED MISUSE



THE USER MUST OBTAIN APPROVAL AND GUIDELINES FROM THE MANUFACTURER ON SPECIAL OPERATING METHODS OR CONDITIONS NOT COVERED IN THOSE SPECIFIED BY THE MANUFACTURER

The machine has been manufactured in accordance with the health and safety requirements of Machinery Directive 2006/42/EC and harmonised standard UNI EN 3691-5:2020.

SECTION 4. PREPARATION AND INSPECTION

GENERAL INFORMATION

This section illustrates the necessary precautions for the lifter to be used correctly and safely. To assure correct use of the machine, it is essential to establish a daily routine procedure based on the instructions provided in the manual. Furthermore, to guarantee safe operation of the machine, a skilled person should establish a maintenance schedule based on the information provided in this manual, which must be strictly complied with.

The owner/user/operator/machine lessor company/lessee of the machine, shall not accept responsibility for its operation before having carefully read the manual and completed training and the operating procedures, guided by an experienced, skilled operator.

For further information relating to safety, training, inspection, maintenance, application and operation, contact Faraone Industrie Spa.



**FAILURE TO COMPLY WITH THE SAFETY PRECAUTIONS LISTED IN THE MANUAL
MAY DAMAGE THE MACHINE AND PROPERTY AND CAUSE INJURIES OR FATAL
ACCIDENTS**

PERSONNEL TRAINING

The lifter is a device that lifts and transports loads; therefore, it must be used and undergo maintenance exclusively by trained personnel.

The machine cannot be used by persons under the influence of alcohol or drugs or subject to epileptic seizures, dizziness or loss of physical control.



Operator training

Operator training must include the following:

1. Use and controls of the lifter;
2. Signs/decals for controls, instructions and warnings on the lifter;
3. Regulations defined by the employer and government regulations;
4. Sufficient knowledge of the mechanical operation of the lifter to be able to recognise a fault;
5. Safe methods for using the lifter in the presence of obstacles, other moving equipment, hollows, holes and slopes.

Training supervision

Training must be carried out under the supervision of a skilled person, in an open space and clear of obstacles and must continue until the trainee is able to safely operate and use the lifter.

Operator responsibility

The operator must be trained with regard to responsibility and authority to stop the lifter in the event of a fault or other unsafe condition, both relating to the lifter and to the work area.

NOTE: the owner must provide qualified personnel for training, internal or external to the company, both at the time of delivery of the first units and later, if requested by the user or personnel.

FULL INSPECTION BEFORE USE

Machine inspection



Start the "full" inspection from point (a), as set out in the following list. Proceed around the lifter checking all listed conditions in sequence.



TO PREVENT ANY INJURIES, ENSURE THAT THE MACHINE POWER SUPPLY IS SWITCHED OFF DURING THE "FULL INSPECTION".
DO NOT FAIL TO CARRY OUT A VISUAL INSPECTION OF THE LOWER PART OF THE BASE FRAME. ENSURE THE AREA IS CLEAR OF OBJECTS OR DEBRIS THAT MIGHT CAUSE SERIOUS DAMAGE TO THE MACHINE.

Inspection of the workplace



- (a) **Fixed wheels and castor wheels** – Check there is no debris on the wheels or around them. Check the integrity of the wheels and the support flanges. Check that they are firmly anchored to the structure;
- (b) **Base frame** – Check that there is no damage, cracks, breakage or unsecured components;
- (c) **Loading forks** – Check there are no dents, breaks or cracks on the profiles. Check the effectiveness of the locking knobs
- (d) **Outriggers** – Check there are no dents, breaks or cracks on the profiles. Check the effectiveness of the locking knobs;
- (e) **Lifting structure unit** – Structure profiles, sliding inserts, chain, pulleys able to turn freely. Check that there are no damages, cracks, breakages or loose components.
- (f) **Batteries (electric version)** - Charge if necessary;
- (g) **Control console (electric version)** - Controls securely fixed, legible markings, emergency stop switch in reset position for operation, legible control markings.



DO NOT USE THE LIFTER UNTIL ALL FAULTS/DEFECTS HAVE BEEN REPAIRED

FUNCTIONAL TEST

At the end of the DAILY INSPECTION perform a functional check of all the machine's systems in an area free of overhead obstacles and at ground level.



IF THE LIFTER DOES NOT WORK PROPERLY, NOTIFY THE MAINTENANCE PERSONNEL OF THE PROBLEM. DO NOT USE THE LIFTER UNTIL IT IS DEEMED SAFE TO USE.

Carry out a functional test as detailed below.

- a. (Electric version) Ensure that all machine functions are disabled when the emergency stop button is activated (pressed);
- b. Lift and lower the loading forks;
- c. Check correct operation of the castor wheel locking brakes.

SAFETY WARNINGS FOR OPERATORS

Do not install and use the lifter in the following cases:



NEAR OVERHEAD OBSTACLES (POWER LINES, OVERHANGS, ETC.) (RISK OF ELECTROCUTION, SHOCK AND COLLISION)



OUTDOORS AND IN WINDY CONDITIONS UNLESS THE MACHINE IS DESIGNED FOR OUTDOOR USE (DANGER OF LOSS OF STABILITY AND OVERTURNING)

WITH LOADS EXCEEDING THE PERMITTED LIMITS (DANGER OF LOSS OF STABILITY AND OVERTURNING)

ON FLOORS WITH STRENGTH LESS THAN THE WEIGHT OF THE MACHINE (DANGER OF LOSS OF STABILITY AND OVERTURNING)

IN ANY CIRCUMSTANCE NOT SPECIFICALLY INDICATED UNDER THE OPERATING CONDITIONS IN THIS MANUAL (GENERAL DANGER)



THE ELECTRICAL SYSTEM OF THE MACHINE IS NOT EXPLOSION-PROOF (NO ATEX): THEREFORE ITS USE IN AREAS SUBJECT TO ATEX RISK SHOULD BE STRICTLY AVOIDED

It is forbidden to overload the loading forks beyond the indicated limits

It is forbidden to use the lifter as a machine to transport/lift people and/or animals

It is forbidden to remove or tamper with the lifter's safety and protection devices

It is forbidden to increase the outreach or loading height of the forks by using additional equipment

It is forbidden to cause oscillations on the lifter so as not to destabilise it

It is forbidden to lift loads while people are passing near the machine

It is forbidden to lift unbalanced loads

It is forbidden to load the forks only on one side or on a single point. The load must be evenly distributed on both forks so that the centre of gravity is about 300 mm from the stop

It is forbidden to use the fork ends as levers to lift loads



It is forbidden to use the lifter on surfaces that are not perfectly flat and smooth and/or with insufficient resistance to support the load (lifter + maximum nominal capacity)

It is forbidden to lift loads that may change their static configuration and/or their centre of gravity

It is forbidden to use the lifter in applications where potential accidental movement may occur

It is forbidden to leave the loaded lifter unattended

It is forbidden to carry out abrupt manoeuvres with the lifter loaded

It is forbidden to allow untrained personnel use the lifter

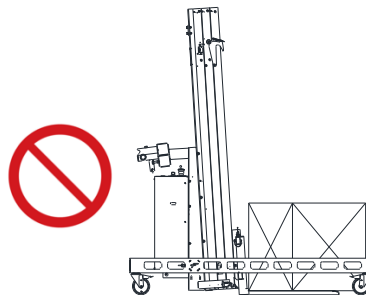
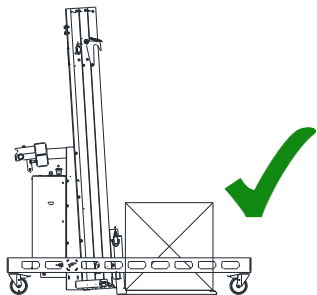
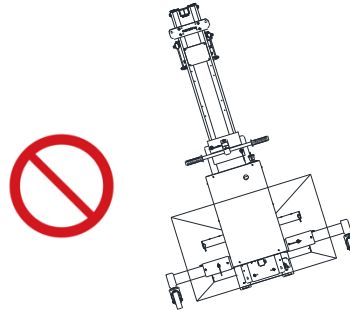
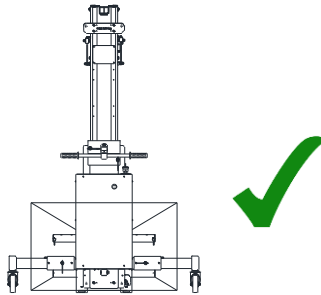
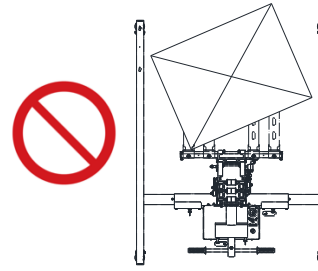
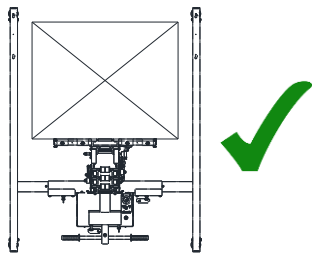
Prohibition of lifter use if you are not psychophysically fit

It is forbidden to use the lifter without due attention

It is forbidden to use the lifter in unforeseen environmental conditions

It is forbidden to use the lifter in environments that are not sufficiently illuminated

WARNINGS FOR LOADING MODE



CORRECT load configurations

INCORRECT load configurations

Manual handling of loads entails a risk of abrasion and crushing of the hands and crushing of the feet resulting from incorrect manoeuvres.

The Manufacturer recommends using the following personal protective equipment for safe use of the machine:



Protection of lower limbs

NON-SLIP SHOES



Protection of the upper limbs

GLOVES AGAINST MECHANICAL RISKS



Protection of the head

PROTECTIVE HELMET



THE POSSIBLE USE OF ADDITIONAL SPECIFIC PERSONAL PROTECTIVE EQUIPMENT, WHETHER DURING USE OF THE MACHINE, DURING MAINTENANCE OR DURING ITS TRANSPORT, MUST BE VERIFIED ON THE BASIS OF THE SPECIFIC RISK ASSESSMENT CARRIED OUT BY THE EMPLOYER/SAFETY MANAGER

SECTION 5. LIFTER USE

INTRODUCTION



THE MANUFACTURER DOES NOT HAVE ANY DIRECT CONTROL OVER LIFTER APPLICATION AND OPERATION. THE USER AND OPERATOR ARE REQUIRED TO COMPLY WITH THE CORRECT SAFETY PROCEDURES.

The lifting device is **INTENDED TO LIFT THE LOAD AND THE OPERATOR IS ON THE GROUND**. The operator can lift and lower the loading forks from the lifter's control station. The lifter is moved by pushing it manually. Vibrations generated by the machine do not pose a danger to the operator. The level of continuous sound pressure (A measurement) at the machine is less than 70 db (A).

BATTERY CHARGE (electric version)

The machine is fitted with a battery charger with AC voltage input/DC voltage output. The battery charger automatically stops charging when the batteries are fully charged



KEEP SPARKS, NAKED FLAMES OR CIGARETTES AWAY FROM THE BATTERIES. PROVIDE ADEQUATE VENTILATION WHILE CHARGING. DO NOT CHARGE A FROZEN BATTERY.

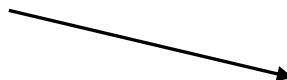
NOTE: when the battery charger is connected to an AC socket, the machine's movement function is deactivated.

Battery charging procedure

1. Park the lifter in a well-ventilated area, near an AC electric socket;
2. Turn the main switch to OFF and remove the key;
3. Connect the battery charger to a correctly installed and earthed socket according to regulations in force.
4. The display (fig.1) shows the battery charge status and charging progress.

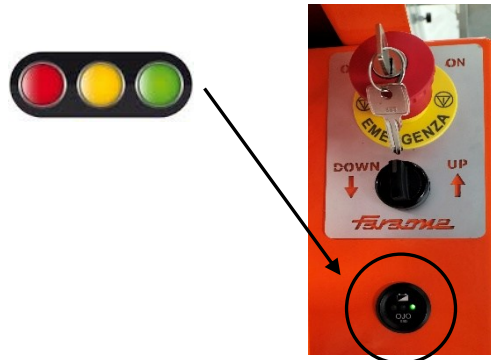


Fig.1



Battery charge status lights while the lifter is in use

The battery charge status lights are located on the bottom of the machine's control console, visible after switching on the machine with the key.



While using the machine, the battery charge will change from fully charged (indicated by the green LED), to partially charged (indicated by the orange LED) to low battery (indicated by the red LED).

Perform the following operations carefully:

- ✓ Charging must be carried out in a well-ventilated area, where it is forbidden to smoke and use naked flames;
- ✓ It is recommended to avoid using any possible source of sparks near charging batteries;
- ✓ It is recommended to use anti-static clothing;
- ✓ Do not lift or tilt the batteries;
- ✓ Do not attempt to start the machine;



IT IS RECOMMENDED TO NEVER LET THE BATTERIES GO COMPLETELY FLAT.



WHEN THE MACHINE IS PUT OUT OF SERVICE FOR A LONG TIME, THE BATTERIES MUST BE FULLY AND EVENLY CHARGED AT LEAST ONCE A WEEK AND STORED UNPLUGGED TO PREVENT THEM FROM GOING FLAT.

LIFTER CONTROL CONSOLE (electric version)



1. Emergency stop/switch-off button with removable key;
2. Load fork up/down selector.

General information

Before operating the machine from the control desk, the following conditions of the controls must be met:

- The battery voltage must be sufficient to operate the machine.
- The emergency stop / switch-off button with removable key must be on RESTORE.

Emergency stop/switch-off button with removable key

- The emergency button located in the control console is provided with a removable key to prevent the lifter from being used by unauthorised personnel. Press the button and remove the key to disconnect the general power supply.



POWER SUPPLY DISCONNECTION

PUSH INWARDS to engage the emergency stop.



POWER SUPPLY CONNECTION

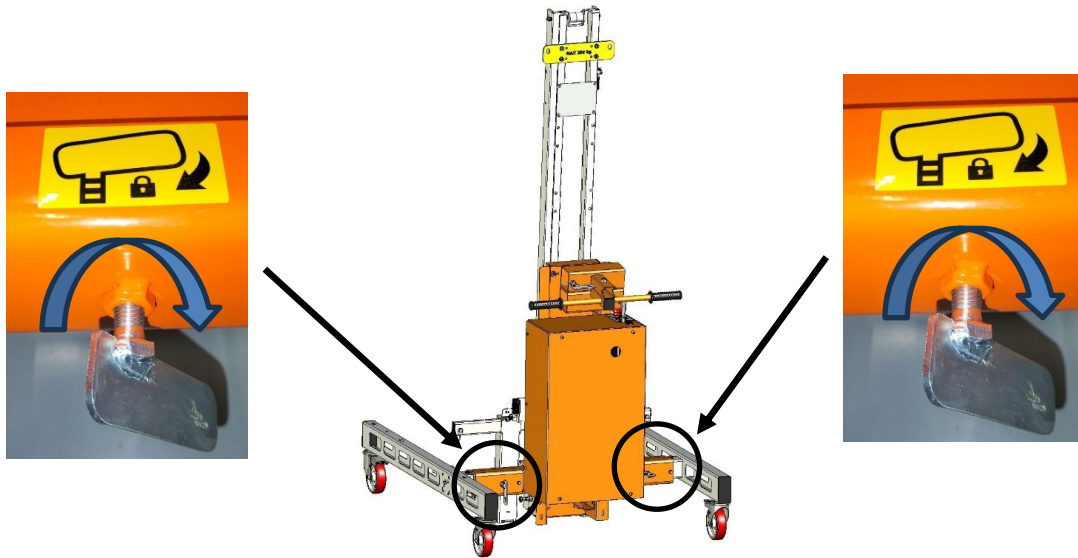
TURN clockwise and RELEASE to restore the emergency stop.



PREVENT UNAUTHORISED USE BY SWITCHING THE MACHINE OFF AND REMOVING THE KEY WHEN THE LIFTER IS NOT IN USE.

ASSEMBLING/DISMANTLING THE OUTRIGGERS (electric version)

The electric version machine is delivered without the stabilizers already assembled. To install them, it will be necessary to lift the machine using a suitable lifting system: forklift (holding the machine on the forks from below) and/or winch (lifting it using the yellow grip plate on the top of the extendable structure). Once assembled, the stabilizers should not be removed if the machine cannot be supported in a stable position without them.



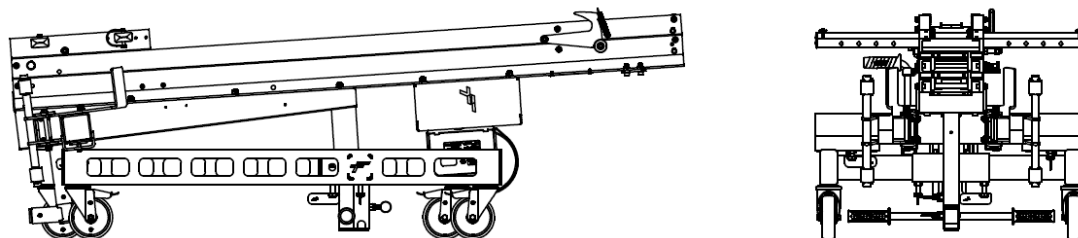
BEFORE USING THE MACHINE, TAKE CARE TO FIRMLY TIGHTEN THE OUTRIGGER LOCKING HANDLE ON THE BASE FRAME

ASSEMBLING/DISASSEMBLING THE OUTRIGGERS (manual version)

The assembly/disassembly of the stabilisers is only permitted on the manual version of the lifter.



THE DISASSEMBLY OF THE OUTRIGGERS MAKES IT POSSIBLE TO RETAIN THE COMPACT CONFIGURATION OF THE LIFTER IN ORDER TO FACILITATE ITS MOVEMENT AND/OR TRANSPORT.



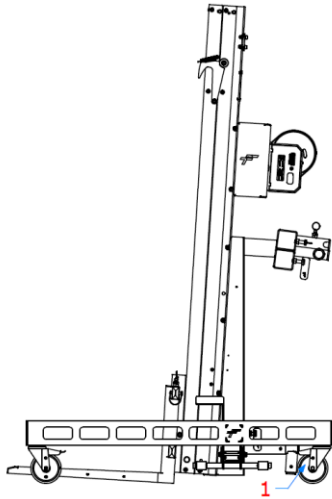
From the manual versions available, however, this operation can only be carried out by the operator for the HW, HW BIG1 and HW BIG2 versions, which are not particularly heavy; the BIG3 and BIG4 versions are heavier and it is impossible to dismantle the outriggers without the aid of external load handling equipment.



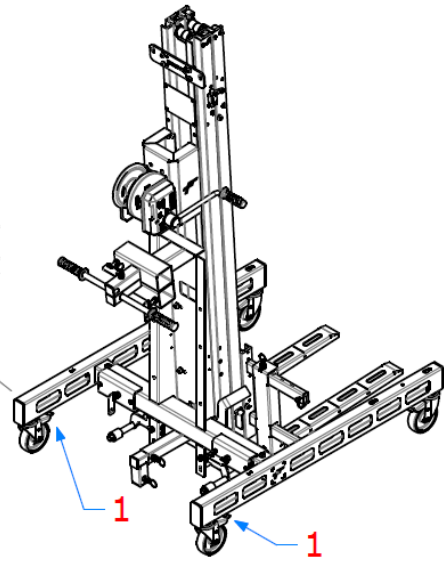
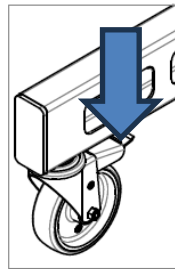
CARRY OUT THE ASSEMBLY/DISASSEMBLY OF THE OUTRIGGERS EXCLUSIVELY FOR THE MANUAL VERSIONS BIG1 AND BIG2.

To disassemble the stabilisers and obtain a version of the lifter in COMPACT MODE, proceed as follows (to reassemble the outriggers, carry out the various steps in reverse order):

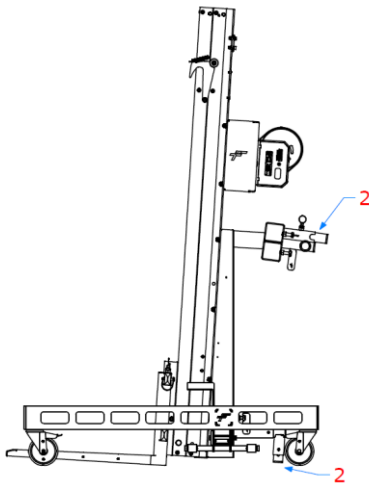
PHASE 1



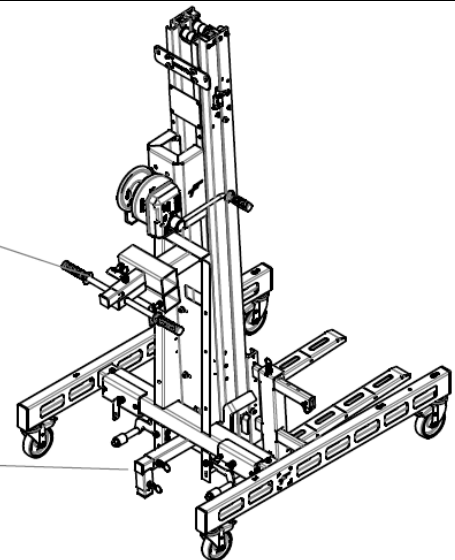
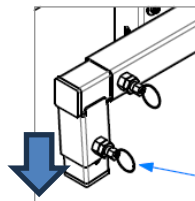
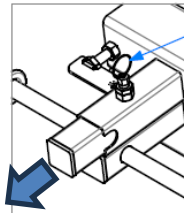
1. BRAKE THE REAR WHEELS AS IN THE PICTURE



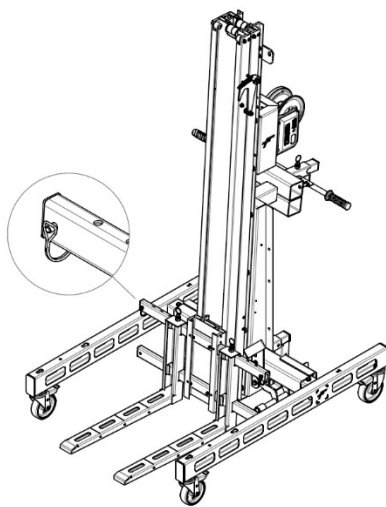
PHASE 2



2. PULL THE SPRING-PIN EYELET AND LET THE SUPPORT FOOT OUT

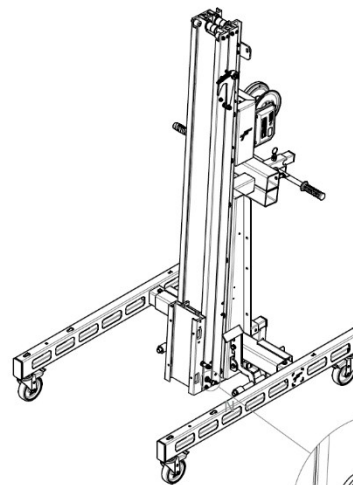


PHASE 3

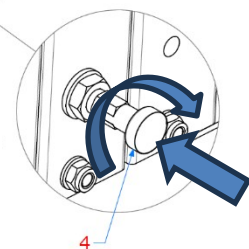


3. REMOVE THE COTTER PINS AND REMOVE THE FORKS FROM BOTH SIDES

STEP 4



4. ROTATE THE SPRING PIN 90° UNTIL IT IS RETRACTED. MAKE SURE THE PROFILE (TROLLEY) IS LOCKED

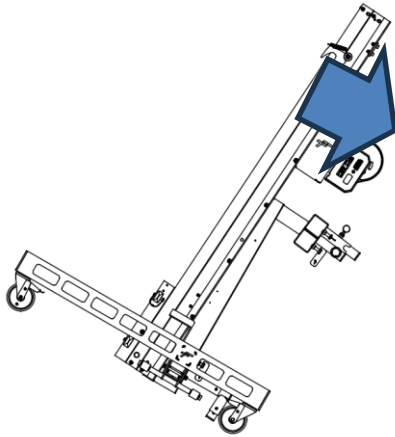




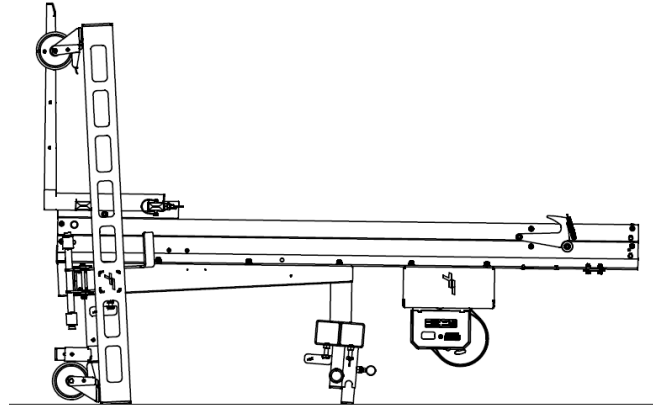
ALWAYS ENSURE THAT THE SPRING PIN IS IN THE WORKING MODE BEFORE USING THE LIFTER.

THE WORKING MODE CONSISTS OF THE PIN BEING PULLED OUT AND ROTATED 90°. IF THE PIN IS NOT IN THIS MODE, THE FORK CARRIAGE WILL NOT LIFT.

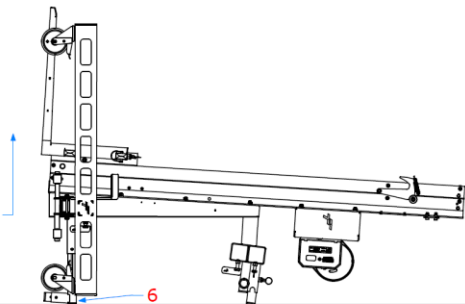
PHASE 5



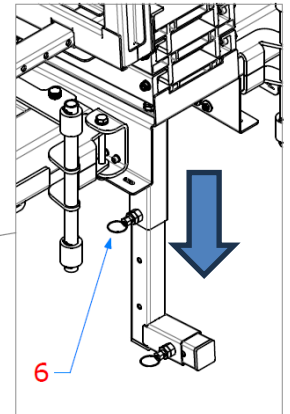
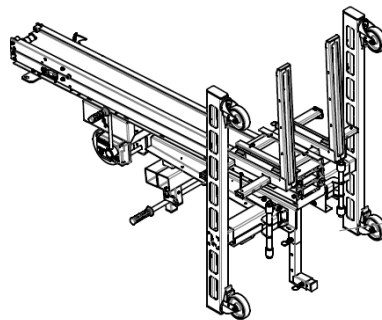
5. PULL THE LIFT TOWARDS YOU AND LAY IT ON THE GROUND IS LOCKED



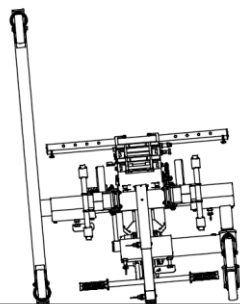
PHASE 6



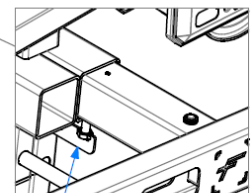
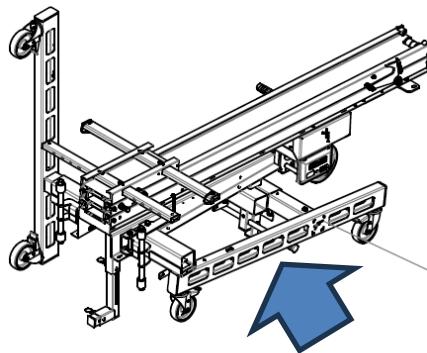
6. LIFT THE STRUCTURE UPWARDS; PULL THE SPRING PIN EYE AND EXTEND THE FOOT COMPLETELY.
6. PLACE THE LIFT ON ITS SIDE



PHASE 7

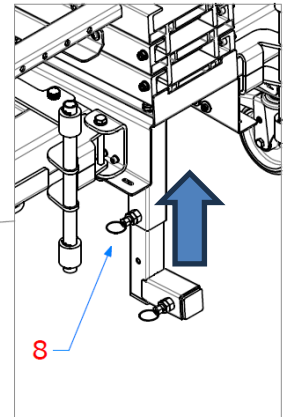
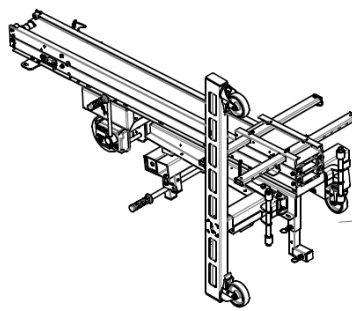
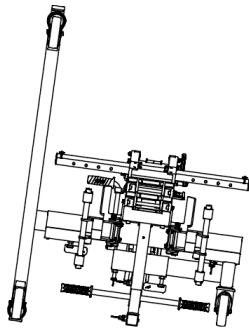


7. AFTER UNSCREWING THE BUTTERFLY, REMOVE THE STABILIZER FROM THE OPPOSITE SIDE, INSERT IT INTO IT'S SEAT ON THE FRAME AND TIGHTEN THE BUTTERFLY TO LOCK IT

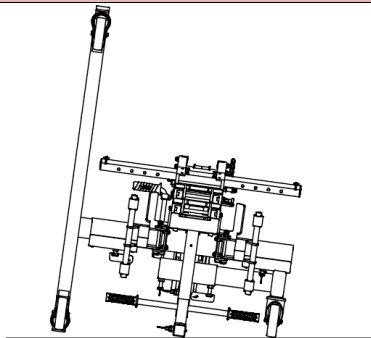


PHASE 8

8. HOLD THE FRAME RAISED;
RELEASE THE SPRING PIN;
RETRACT THE FOOT OF ONE POSITION AND LEAN THE LIFT
ON THE OPPOSITE SIDE.

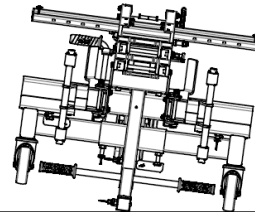


PHASE 9



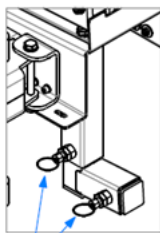
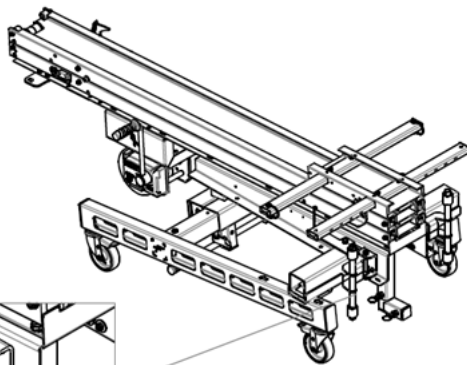
9. AFTER UNSCREWING THE BUTTERFLY
REMOVE THE STABILIZER. INSERT IT INTO THE
FRAME SEAT, TIGHTEN THE BUTTERFLY TO LOCK IT.

PHASE 10

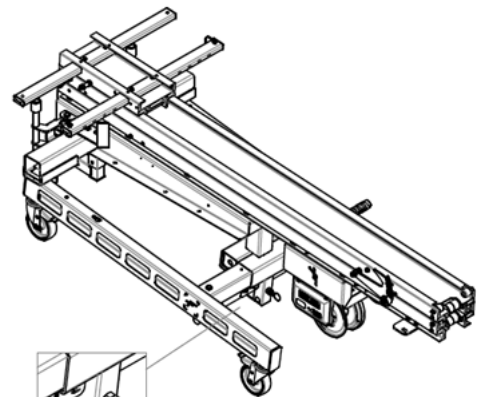


10. RELEASE THE SPRING PINS; RETRACT ALL
THE FEET.

PHASE 10

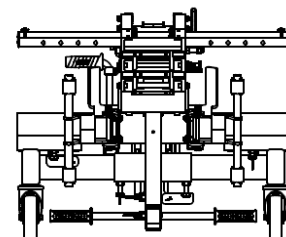
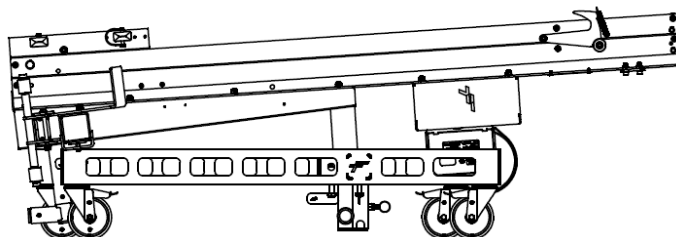


10



10

OVERALL LIFTER IN TRANSPORT MODE



USE OF THE LEVER ASSEMBLY

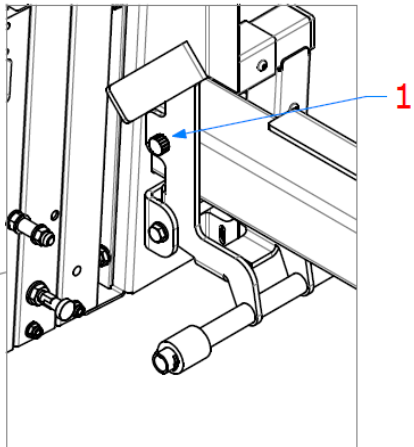
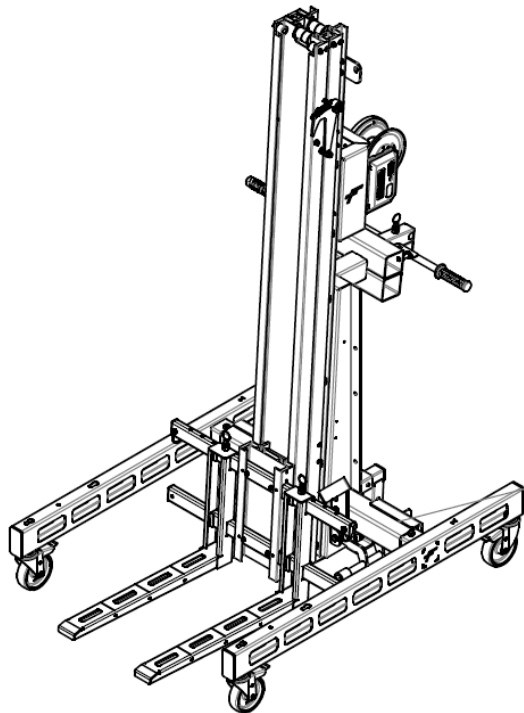
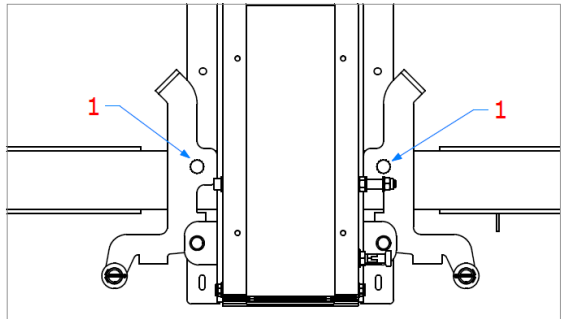
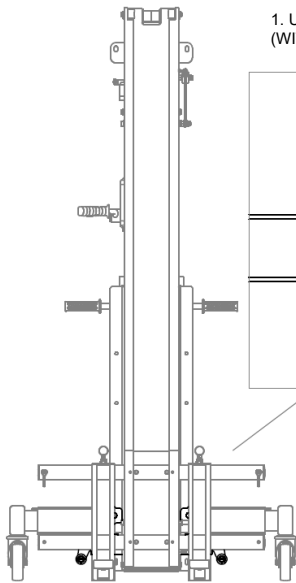
The lever assembly allows the base of the lifter to be lifted when there is a need to interchange the various stabilisation configurations allowed for the specific model (STANDARD FRONT / REAR FRONT / LOWERED FRONT).



**IT IS ABSOLUTELY FORBIDDEN TO USE MIXED OUTRIGGER CONFIGURATIONS ON THE SAME MODEL.
BOTH OUTRIGGERS MUST BELONG TO THE SAME CONFIGURATION AND HAVE THE SAME IDENTIFICATION NUMBER (SEE SPECIFIC TABLE).**

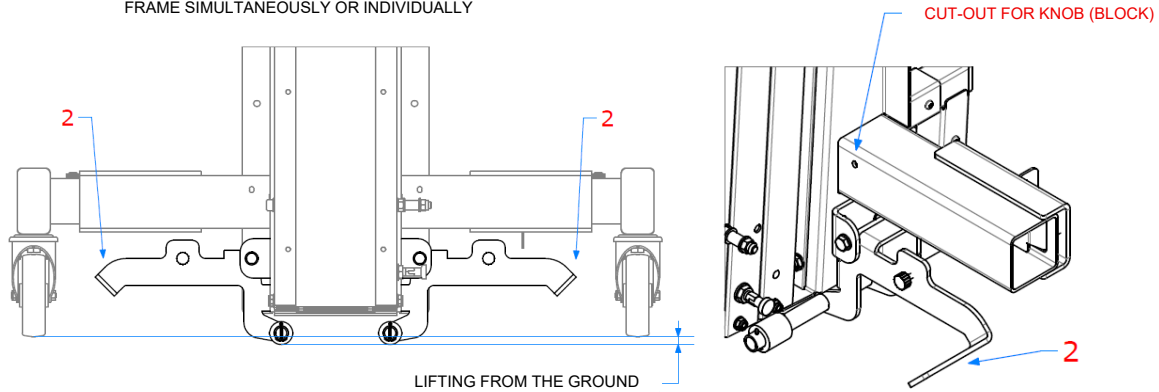
PHASE 1

1. UNSCREW THE KNOBS UNTIL THE LEVERS ARE UNLOCKED (WITHOUT RELEASING THEM FROM THE THREADED SEAT)



PHASE 2

2. FORCE DOWN ON LEVERS UNTIL THEY SIT ON THE FRAME SIMULTANEOUSLY OR INDIVIDUALLY

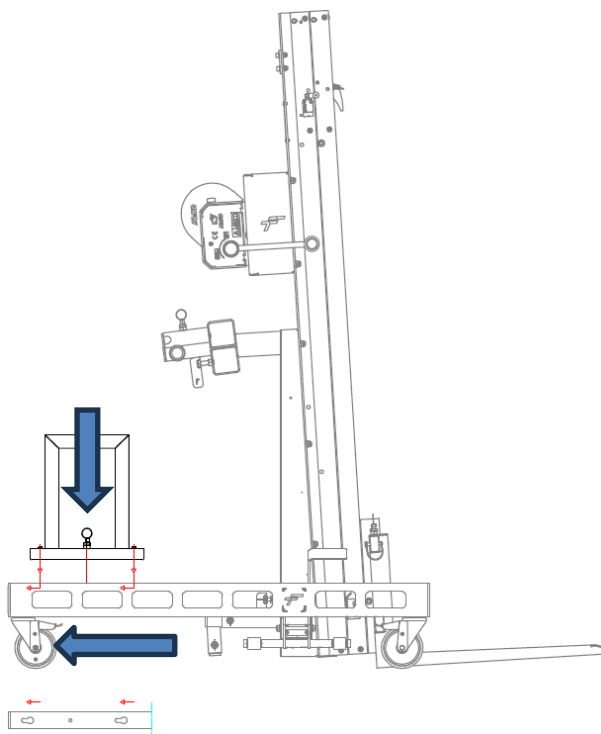


After replacing the outriggers, lift the levers upwards and secure them again by means of the knobs in position (1).

MOUNTING THE BALLAST KIT

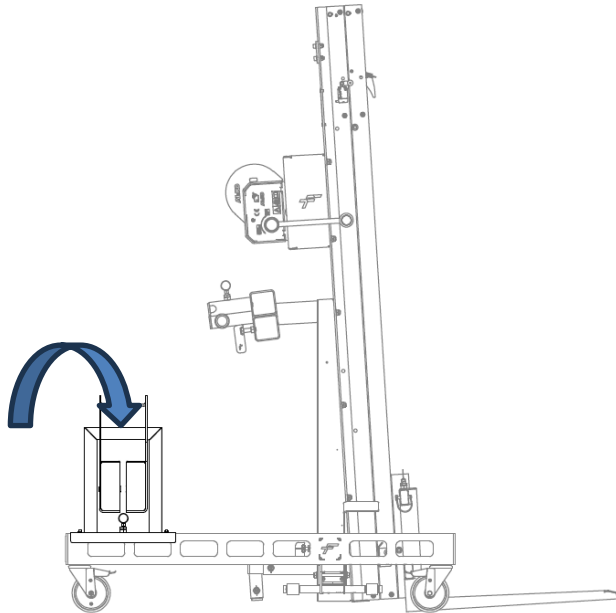
The use of the BALLS KIT is mandatory when the lifter is used with the "REAR" stabilisation version. For assembly proceed as follows:

PHASE 1



ENGAGE THE BRACKET ON THE OUTRIGGER BY CENTRING THE TWO CIRCULAR HOLES ON THE OUTRIGGER; THEN SLIDE IT UNTIL THE SPRING PIN SNAPS IN.
 THE SPRING PIN WILL NOT ALLOW RELEASE WITHOUT PULLING THE RING UPWARDS.
 OPERATION TO BE CARRIED OUT ON BOTH OUTRIGGERS.
 ENSURE THAT THE SUPPORTS ARE FIRMLY ATTACHED TO THE OUTRIGGERS.

PHASE 2



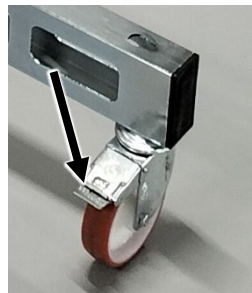
APPLY ONE OR TWO BALLASTS PER STABILISER ACCORDING TO THE VALUE GIVEN IN THE TABLE DEPENDING ON THE LIFTER CONFIGURATION USED.



IT IS ABSOLUTELY FORBIDDEN TO USE THE 'REAR' STABILISATION WITHOUT ASSEMBLING THE BALLAST KIT AND WITHOUT ASSEMBLING THE REQUIRED NUMBER OF BALLAST WEIGHTS FOR THE PARTICULAR LIFTER MODEL.

LIFTING / LOWERING THE LOAD

During the load lifting/lowering stages, the four wheels of the outriggers must have the brakes engaged in order to prevent unwanted movements of the lifter.



NOTE: To lock the wheel brake, firmly press the lever, using the toe of the foot, so that it remains in a fully lowered position.

To unlock the wheel brakes, press the lever with a small flick of the toe (**ATTENTION**, do not use your hands).



BEFORE LIFTING/LOWERING THE LOAD, BE SURE TO ENGAGE THE WHEEL PARKING BRAKES.

In the case of an electric lifter, the lifting/lowering of the forks is controlled by the up/down control. In the case of a manual hoist, the lifting/lowering of the forks is instead handled by a manual winch.



ESPECIALLY DURING THE LOWERING OF THE FORKS, TAKE CARE NOT TO SET AN UNCONTROLLED CRANK SPEED. SHOULD THE HAND LOSE ITS GRIP ON THE CRANK, IT COULD ROTATE UNCONTROLLABLY AND RISK HITTING THE HAND.

MOVING THE LIFTER FORKS

In order to adjust the lifter forks to the desired width so that load handling can be carried out safely, the following steps must be carefully followed:

1. **Preparation:** Ensure that the hoist is placed on a flat, stable surface. Switch off the motor (electric version) and apply the safety brakes to prevent accidental movement.
2. **Unlocking Pins:** Locate the spring pins that secure the forks. To unlock, grasp the ring on the pin and pull firmly (fig. 1). This will allow free movement of the pin.
3. **Width Adjustment:** Once the pins are unlocked, the forks can be widened or tightened as required. Ensure that the forks are arranged in a balanced manner and that there are no obstacles during movement.
4. **Restoring the Pins:** After securing the forks in the desired position, reinsert the spring pins into their respective slots. Make sure that they are fully inserted and that the safety ring is back in place to ensure a secure closure.
5. **Final Verification:** Before resuming use of the lifter, visually check that the forks are secure and the pins are fully engaged.

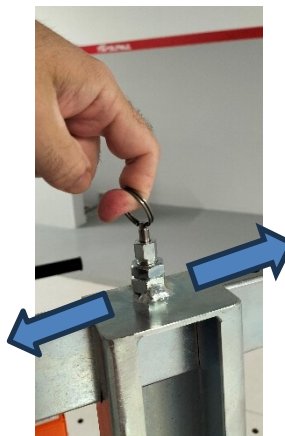


Fig 1



BEFORE LIFTING / LOWERING THE LOAD, VERIFY COMPLIANCE OF ALL THE SAFETY WARNINGS OF THE OPERATORS PROVIDED IN THE PREVIOUS PARAGRAPHS.



BEFORE LOADING THE MATERIAL, CHECK THAT THE SPRING PINS LOCKING THE FORKS AND THE STABILISER KNOBS ARE SUFFICIENTLY TIGHTENED.



AVOID LIFTING/LOWERING THE LOAD IF YOU BELIEVE THAT THE LOADING OR LIFTING DEVICE IS NOT FUNCTIONING PROPERLY OR IS DAMAGED AND ARRANGE FOR IT TO BE REPAIRED (CONTACT THE MANUFACTURER IF NECESSARY).

LOAD LIFTING OPERATIONS

1. Place the load to be lifted on the forks;
2. Actuate the lifting control (electric version) or manoeuvre the manual winch by turning the handle clockwise (manual version).

LOAD LOWERING OPERATIONS

For the load lowering operation, it is necessary to perform all the operations described in the previous point in the opposite direction (the crank of the manual winch must be turned anti-clockwise).



(MANUAL VERSION) THE WINCH CRANK IS EQUIPPED WITH A FRICTION BRAKE WITH AUTOMATIC ENGAGEMENT.
AT ANY POSITION AT A HEIGHT OF THE LOAD, INTERRUPTING THE ROTATION OF THE HANDLE WILL AUTOMATICALLY BLOCK THE EXTENDIBLE STRUCTURE. SHOULD THE AUTOMATIC FRICTION CLUTCH NOT TO BE ABLE TO HOLD THE LIFTED LOAD, IT IS REQUIRED TO ADJUST IT; USE THE INSTRUCTIONS PROVIDED WITHIN THE HOIST USER MANUAL SUPPLIED WITH THE LIFTER.



(MANUAL VERSION) ESPECIALLY DURING THE LOWERING OF THE FORKS, TAKE CARE NOT TO SET AN UNCONTROLLED CRANK SPEED. SHOULD THE HAND LOSE ITS GRIP ON THE CRANK, IT COULD ROTATE UNCONTROLLABLY AND RISK HITTING THE HAND.

MOVING THE LOAD

To move the load after having placed it on the forks of the lifter, it is required to lower the load to the ground, in order to avoid any danger of overturning of the load and/or overturning of the lifter.



DO NOT MOVE THE LIFTER WITH A LIFTED LOAD. BEFORE MOVING THE LIFTER, ALWAYS LOWER THE TRANSPORTED LOAD.

PARKING THE LIFTER

The lifter does not need to undergo specific treatments if it is not used for long periods. Make sure that it is protected from the effects of weathering.

1. Move the lifter to an area where it cannot obstruct working activities and/or transit areas;
2. Make sure that the load support is completely lowered;
3. It is advisable to leave the outriggers mounted in order to make the machine more stable and to lock the wheels by the specific brakes so as to avoid involuntary movements;
4. (Manual version) If the outriggers are removed, store them carefully, and when parking the lifter, leave the forks all the way down in order to provide the machine with greater stability and safety.



NOTE: (electric version) if necessary, charge the batteries in preparation for the next working day.



IT IS RECOMMENDED TO PARK THE MACHINE PROTECTED FROM WEATHERING



(ELECTRIC VERSION) IT IS RECOMMENDED TO ALWAYS SWITCH OFF THE MACHINE AND REMOVE THE KEY WHEN NOT USING THE LIFTER, IN ORDER TO PREVENT UNAUTHORISED USE.

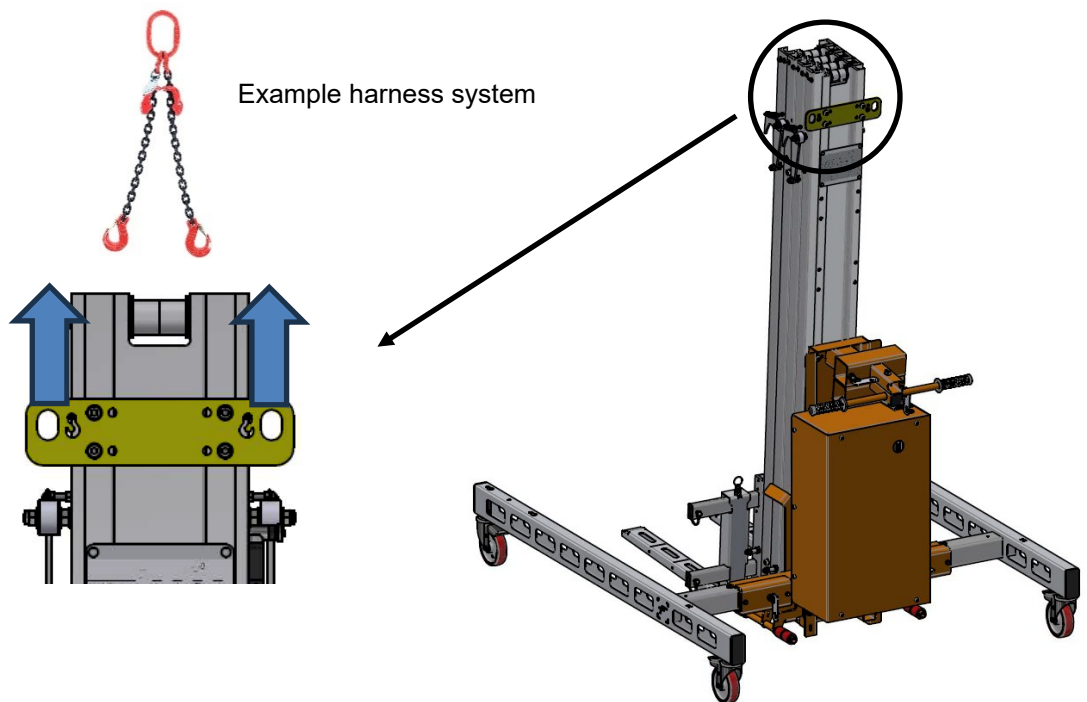
TRANSPORT AND LIFTING PROCEDURES



DURING TOWING, LIFTING AND TRANSPORT, DO NOT ALLOW PERSONNEL AND/OR EQUIPMENT TO STAND IN THE LOADING FORKS OR IN ANY OTHER PART OF THE LIFTER

To ensure a safe and effective transfer of the machine, carefully follow these lifting instructions, using the designated attachment points.

1. **Preparation:** Ensure that the surrounding area is free of obstacles, that the machine is switched off (electric version) and that it is stably positioned. Wear personal protective equipment (PPE) appropriate to the operation.
2. **Identification of Docking Points:** Locate the specified attachment points (fig.1). These points are designed to support the weight of the machine and ensure safe lifting.
3. **Connection of Lifting Instruments:** Use suitable lifting equipment such as hooks, ropes or chains. Ensure that they are properly secured at the attachment points, avoiding any movement or slippage during lifting.
4. **Verification:** Carry out a visual check to ensure that everything is correctly positioned and that the attachment points show no signs of wear or damage.
5. **Lifting the machine:** Use lifting equipment to raise the machine in slow, controlled movements. Ensure that the load is balanced and stable throughout the process.
6. **Transfer:** Once raised, move the machine to the new desired position. During the transfer, always maintain control and stay close to the load.
7. **Positioning:** Position the machine carefully, lowering it slowly and evenly until it reaches the ground.
8. **Removal of Lifting Equipment:** Once the machine is completely on the ground and stable, remove the lifting gear carefully.





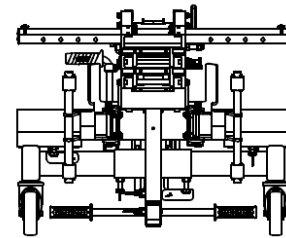
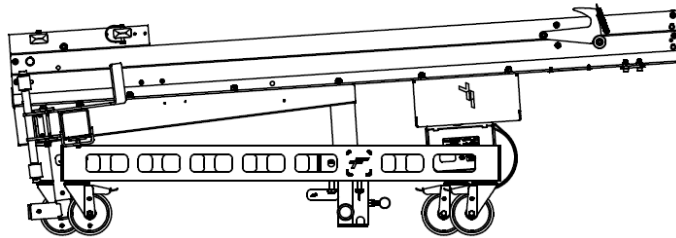
LIFT THE MACHINE ONLY WITH THE FORKS FULLY LOWERED

LOAD THE MACHINE, ONLY IN A VERTICAL POSITION, ONTO A HEAVY DUTY VEHICLE HAVING A USEFUL LOAD CAPACITY THAT WITHSTANDS THE TOTAL WEIGHT OF THE MACHINE

SECURE THE MACHINE SO THAT IT DOES NOT GET DAMAGED DURING TRANSPORT

TRANSPORT IN COMPACT MODE (manual version)

The manual lifter versions can be compacted to allow tipping in a horizontal position to facilitate transport of the machine when not in use. For operating instructions please refer to the section ASSEMBLY / DISASSEMBLY OF THE OUTRIGGERS (manual version).



REPORTING THE INCIDENT

Faraone Industrie Spa must be immediately informed of any incidents involving a Faraone product. Contact the manufacturer by telephone and provide all the necessary details even if there are no obvious injuries or damage to the property.



AFTER AN INCIDENT, INSPECT THE ENTIRE MACHINE AND CHECK ALL FUNCTIONS. DO NOT USE THE LIFTER UNTIL YOU ARE SURE THAT ALL DAMAGE HAS BEEN REPAIRED, AS REQUIRED, AND THAT ALL CONTROLS FUNCTION CORRECTLY

SECTION 6. OPTIONAL

HW BALLAST KIT



The kit consists of 2 base supports and necessary ballasts, depending on the HW model selected. Useful when you have obstacles on the ground that do not allow you to properly approach the work area.

PLANE WITH ROLLER CONVEYORS



Plane with bidirectional roller conveyors. This optional feature is used to facilitate the positioning of the load on the pre-established decks at a height. It has eight adjustable rollers, horizontally or vertically, to easily slide the load on, to place it in the desired position.

SWING ARM



Swing arm consisting of the pipe lock and rotation system to be able to pick up the roll from the ground, rotate it and place it in a horizontal position. Internal pipe from 75 to 150 mm. Max. capacity 150 kg.

ADJUSTABLE FORKS



Width adjustable forks with shims to pick up and position barriques.

REEL PICK-UP PIPE



Pipe to pick up reels with electric extractor, max extraction weight 50 kg.

SPECIAL BASE



Special low-profile outrigger for easy access/pallet access, allowing the HW to be placed under shelves or suspended furniture.

FORKS WITH ROLLER

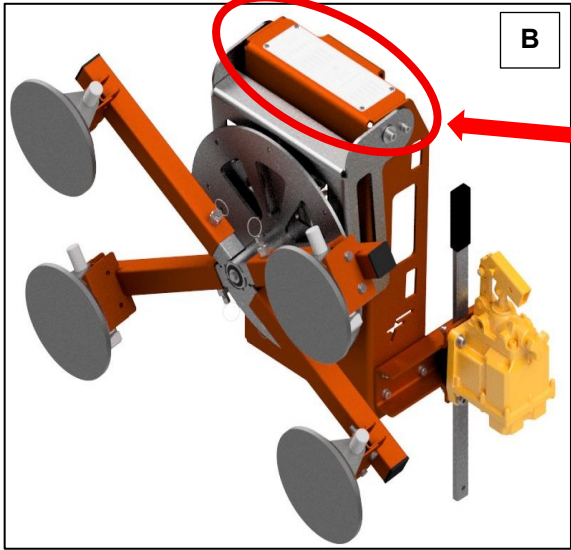
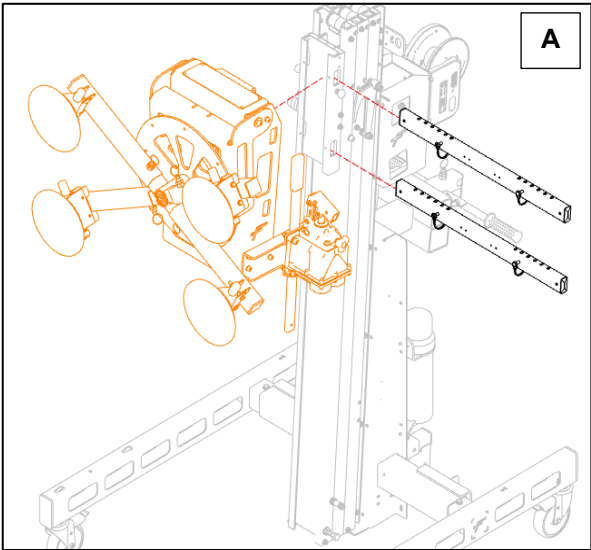


Forks with roller.

SUCTION CUP KIT

GENERAL INFORMATION

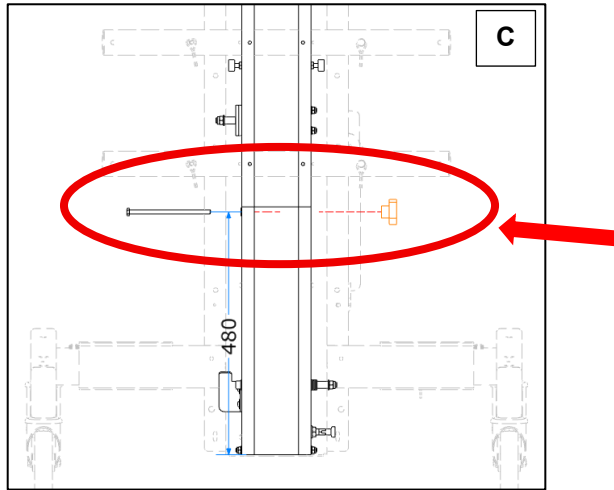
The glass lifting support allows you to easily handle glass or panels with smooth surfaces ; it has to be applied in place of the standard lift forks, directly on the supplied crosspieces (A).



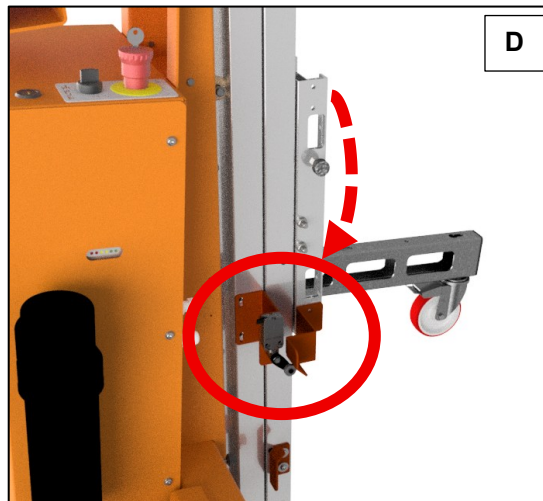
FOR INFORMATION REGARDING THE CAPACITY, REFER TO THE PLATE APPLIED TO THE ACCESSORY (B)

BEFORE USING THE GLASS LIFTING SUPPORT:

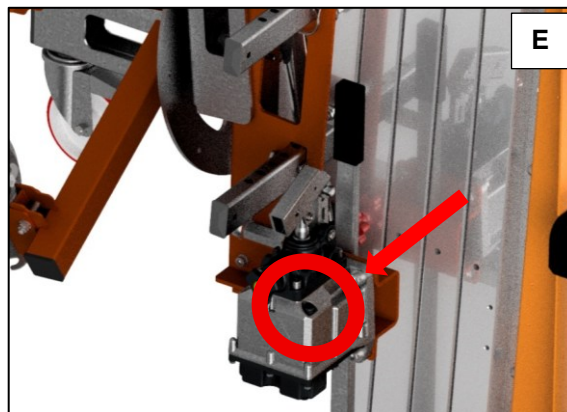
- If assembled on HW02, HW03, HWBIG1, HWBIG2, HWBIG3 o HWBIG4, insert the screw and lock it by screwing the knob into the appropriate hole on the extension to block the trolley from descending to the ground (C)



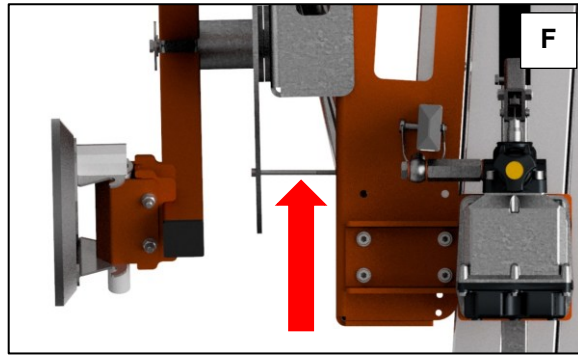
- If assembled on HW02EL, HW03EL, HWBIG1EL, HWBIG2EL, HWBIG3EL o HWBIG4EL, move the micro switch's contact plate to match the holes at the bottom of the trolley (D).



BEFORE USING THE ACCESSORY MAKE SURE TO REMOVE THE CAP ON THE PUMP TANK AND APPLY THE ONE SUPPLIED (E)

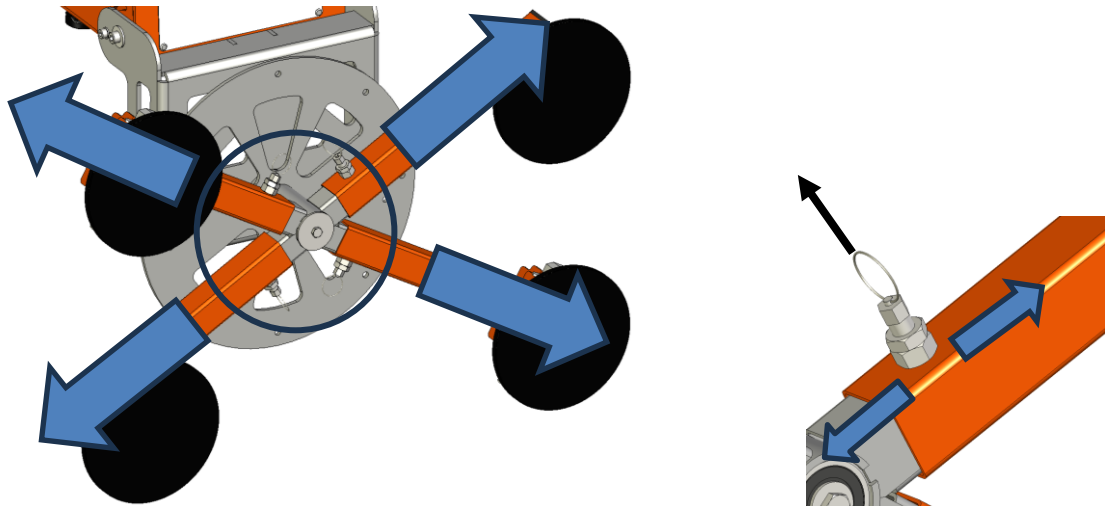


Once the previous steps are completed, remove the locking screw: the device is now ready for use (F).



INSTRUCTIONS FOR USE

To adjust the suction cup gripping position to the size of the glass to be handled, the adjustable arms can be adapted as shown below. Simply lift the arm locking pin and adjust the extension to the desired width.



AFTER MOVING THE ARM TO THE DESIRED POSITION, CHECK THAT THE SPRING PIN HAS RETRACTED COMPLETELY INTO THE CLOSEST SEAT TO ENSURE A SAFE POSITIONING.

LIFTING OF THE GLASS



BEFORE EACH USE, MAKE SURE THE SUCTION CUP IS SMOOTH, CLEAN, INTACT, AND FREE OF CRACKS.
 CLEAN THE SUCTION CUP REGULARLY WITH ALCOHOL OR NON-AGGRESSIVE DETERGENTS.
 MAKE SURE THE SURFACE OR OBJECT TO BE LIFTED IS NON-POROUS. ALSO, THE SURFACE MUST BE CLEAN, DRY, AND FREE OF OIL AND GREASE.
 ON ROUGH OR POROUS SURFACES, THE HOLDING CAPACITY WILL BE DECREASED OR NONE.
 DO NOT USE SHARP OBJECTS TO PULL THE SUCTION CUP FROM THE SURFACE, AS THIS WILL DAMAGE THE PAD.

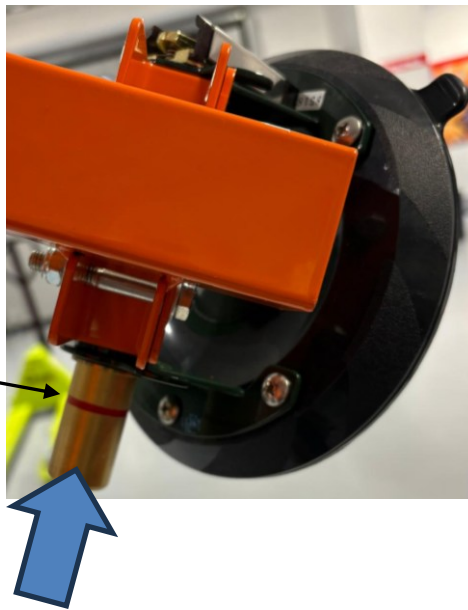
1. Adjust the distance between the suction cup arms according to the size of the glass to be lifted;
2. Lock the lifter's wheels and place the glass on the suction cups;
3. Place the glass on the four suction cups and pump the vacuum by repeatedly pressing the button on each suction cup to adhere to the surface (operate the manual pump until the suction cup adheres completely; when the red line is hidden, the vacuum is sufficient);



**CHECK THE PLUNGER FREQUENTLY TO ENSURE THE SUCTION CUP REMAINS SECURE.
IF THE RED LINE APPEARS DURING LIFTING, IMMEDIATELY LOWER THE LOAD AND PUMP UNTIL THE RED LINE DISAPPEARS AGAIN.**

4. Unlock the lift wheels and reach the desired workstation;
5. Once you reach the working position, immediately lock the lift wheels. Then, operate the lift control to reach the desired height;

**RED LINE
SIGNALLING
VACUUM LIMIT**

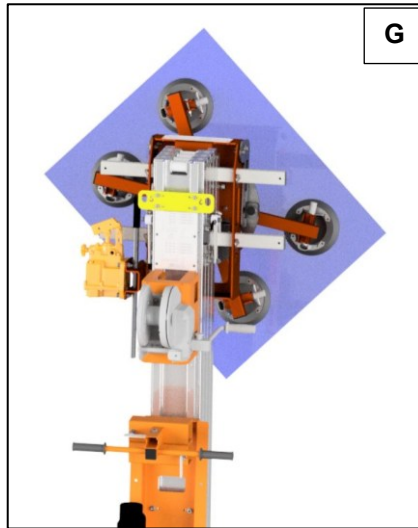


TO ENSURE A CORRECT HOLD OF THE GLASS, ALL FOUR SUCTION CUPS MUST BE ON GRIP.

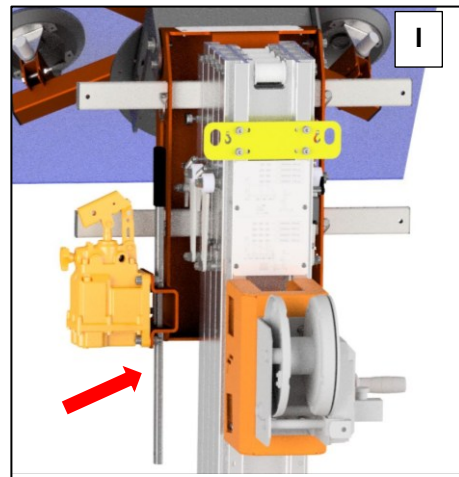
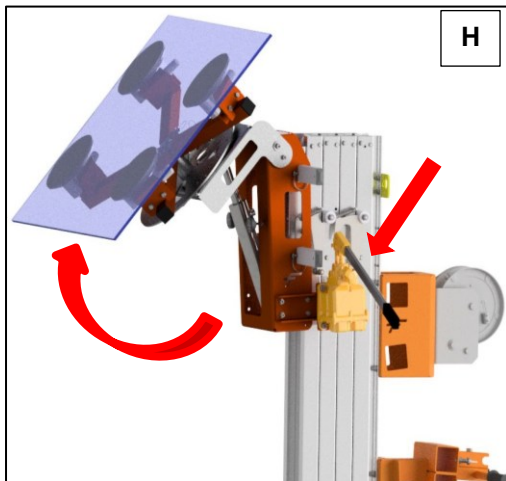


DURING THE GRIP, LIFTING AND LOWERING PHASES OF THE GLASS, THE TWO WHEELS OF THE LIFT MUST BE BRAKED IN ORDER TO AVOID UNEXPECTED MOVEMENTS OF THE LIFT.

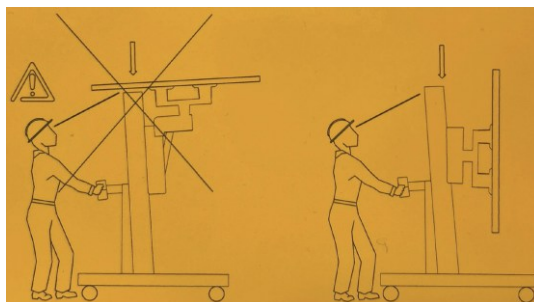
Once locked, the glass can be rotated by acting on the spring pin located on the side. To correctly unlock the system, pull the pin outwards and rotate the plate until it locks into the desired hole (G).



The inclination of the glass can be adjusted using the manual pump located on the side, acting on the appropriate lever (H). When not in use, the lever can be stored behind the pump in the suitable housing (I).



DURING THE ROTATION PHASE OF THE SUCTION CUP ASSEMBLY WITH LOADED GLASS, IT IS ABSOLUTELY IMPORTANT TO CHECK THAT THE GLASS DOES NOT BUMP AGAINST THE STRUCTURE.



SECTION 7. ROUTINE MAINTENANCE

The following Personal Protective Equipment must be worn when carrying out maintenance work on the machine:



PROTECTIVE GLOVES



NON-SLIP SHOES



PROTECTIVE GOGGLES



MAINTENANCE OPERATIONS MUST BE PERFORMED EXCLUSIVELY BY SUITABLY TRAINED PERSONNEL.



IT IS RECOMMENDED TO ONLY USE SPARE PARTS APPROVED BY THE MANUFACTURER.



CONTACT THE MANUFACTURER IF IN DOUBT WITH REGARD TO THE FREQUENCY AND METHOD OF ROUTINE AND/OR EXTRAORDINARY MAINTENANCE ACTIVITIES. DO NOT TAKE INITIATIVES IF UNSURE OF WHAT YOU ARE DOING.



THE RECOMMENDED FREQUENCY OF LUBRICATION AND WEAR CHECKS IS BASED ON NORMAL USE. IF THE MACHINE IS USED FOR HEAVY DUTY WORK, SUCH AS A HIGH NUMBER OF CYCLES, UNFAVOURABLE POSITION, CORROSIVE/DIRTY ENVIRONMENT, ETC., THE USER MUST INCREASE THE FREQUENCY OF THE CHECKS ACCORDINGLY.



FOR FURTHER INFORMATION REGARDING THE PURCHASE OF SPARE PARTS AND CONSUMABLES, PLEASE CONTACT THE MANUFACTURER.
THE MANUFACTURER DISCLAIMS ALL LIABILITY FOR DAMAGE OR MALFUNCTION CAUSED BY USE OF PARTS NOT AUTHORISED BY THE MANUFACTURER.

MONTHLY MAINTENANCE

- **Torque Reducer (electric version)**

Check the oil level, the correct closing of the filler plugs and the absence of lubricant leakage from the torque reducer.

- **General cleaning, condition and cleaning of travel wheels and wheels of the lifting frame**

Cleaning is required to clear the structure and moving elements from dust or dirt build-up. Cleaning must be carried out with the use of means, equipment and detergents or solvents commonly used for cleaning industrial equipment.

Check that all the wheels are not braked; for example, wires, twines, dirt may compromise normal sliding and must therefore be removed.

- **Hoisting winch: checking the effectiveness of the automatic engagement brake**

Should the automatic friction clutch not be able to hold the lifted load, it is required to adjust it; use the instructions provided within the hoist user manual supplied with the lifter.

MAINTENANCE EVERY SIX MONTHS

- **Check there is no clearance, mechanical parts not correctly secured and/or bent and no damaged welds on parts/components;**

- **Check the integrity of the structural profiles;**

- **Torque Reducer (electric version)**

Carry out a thorough cleaning of the outside of the gearbox to remove any dirt deposited over time which could limit the heat dissipation capacity.

- **Battery Check (electric version)**

Check for any corrosion and tightening of the terminals and any acid top-ups required in the battery (if lead/acid type).

- **Checking the controls (electric version)**

Controls secured, legible signs, functioning emergency/main switch, legible control signs.

- **Check the lifting belt**

Check whether the condition of the lifting belt is intact and free from textile fibres that are worn, damaged and/or torn along the edges of the belts and on the terminals. Make sure the belt is not dirty with mud, rubble, ice or other foreign bodies.

- **Check the wheels for wear**

Check there is no debris on the wheels or around them. Check the tread for wear or damage. The wheels must be replaced if the edges are worn or the profiles deformed. If the wheels have significant damage on the tread or sides, immediately assess the severity of the damage before operating the machine again.

- **Motor (electric version)**

Check the diameter and condition of the engine manifold by removing the rear cover and cleaning the inside of it of dust (contact the manufacturer if in doubt about the operating procedure). Check the wear level of the brushes (contact the manufacturer if in doubt about checking and/or replacing them)

- **Lubrication of moving parts and sliding wheels check**

The extensions slide on nylon wheels. Four wheels, two upper and two lower, are fitted for each pair of extensions.

Check for the absence of debris, the integrity of the wheels and the absence of abnormal play/movements (contact the manufacturer for more information and guidance on the possible adjustment of the running wheels of the extensible structure, following the detection of abnormal play).

MAINTENANCE EVERY TWO YEARS

- **Torque Reducer (electric version)**

Inspect the torque reducer, check the tightness of the screws and replace the oil (refer to the instructions in the appropriate section).

MAINTENANCE EVERY FIVE YEARS

- **Lifting belt**

Refer to the instructions in the relative paragraph for information on how to replace the lifting belt.

SECTION 8. MAINTENANCE INSTRUCTIONS**BATTERY MAINTENANCE (electric version)**

It is required to periodically check the terminals for any corrosion as well as for proper tightening. If required, replace the batteries as follows:

1. Make sure the machine is not connected to an external mains supply (charging batteries);
2. Use the specific switch to disconnect the machine's power supply;
3. Open the protective cover of the battery compartment;
4. Loosen the connection terminals of the batteries (positive pole and negative pole);
5. Remove the batteries and replace them with new ones;
6. Connect the terminals of the batteries, making sure to do so correctly (red wire for the positive pole, black wire for the negative pole) and tighten them;
7. Close and lock the protective cover.



SHOULD THE BATTERY BE DAMAGED, USE THE APPROPRIATE PERSONAL PROTECTIVE EQUIPMENT TO PROTECT YOUR HANDS AGAINST CHEMICAL AGGRESSION WHEN REPLACING THE BATTERY. DISPOSE OF THE BATTERIES IN ACCORDANCE WITH THE LAWS IN FORCE. REPLACE THE BATTERIES WITH THE SAME TYPE AS SUPPLIED BY THE MANUFACTURER.

REPLACE DRIVE TORQUE REDUCER OIL (electric version)

PAY ATTENTION BECAUSE DURING NORMAL OPERATION THE SURFACES ARE HOT

Change the waste oil when the reducer is still hot.

Before changing the lubricant, make sure that the product has been at a standstill for about 30 minutes, a sufficient amount of time for the oil temperature to drop to levels which are not hazardous for the operator.

Before introducing new oil, flush out any particles inside the casing using the same type of oil. The new oil must only be added when you are sure that there is no dirt.

Follow these 5 steps to change the oil properly:

1. Place a sufficiently capacious container underneath the drain plug.
2. Remove the filler cap and drain plug, let the lubricant flow out and wait as long as necessary for it to drain completely.
3. Replace the gaskets of the filler cap and drain plug and carefully clean the magnet, if any.
4. Screw the drain plug back on and fit the reducer in its final position.
5. Fill the reducer with new oil until it reaches the level indicated in the cap or sight glass and tighten the filler cap.

LIFT BELT REPLACEMENT



CONTACT ONLY THE MANUFACTURER FOR OPERATING INSTRUCTIONS ON HOW TO REPLACE THE LIFT BELT.

SECTION 9. ATTACHED DOCUMENTATION

- ✓ ANNEX 1 - Information on residual risks;
- ✓ ANNEX 2 - Circuit diagram (electrical version);
- ✓ ATTACHMENT 3 – Declaration of conformity.

ANNEX 1 - Information on residual risks

Below is a list of warnings on the machine to highlight the location of residual risks:

OBLIGATION SIGNS



WEAR SAFETY SHOES



WEAR PROTECTIVE GLOVES



WEAR THE PROTECTIVE HELMET

PROHIBITION SIGNS



DO NOT REMOVE THE SAFETY GUARDS AND DEVICES

DANGER SIGNS



OBJECTS FALLING FROM A HEIGHT



CRUSHING AND ENTANGLEMENT OF UPPER AND LOWER LIMBS



CRUSHING AND TRAPPING OF THE UPPER LIMBS



MACHINE OVERTURNING



OUTRIGGERS LOCK HANDLE CLAMPING LABEL



UPPER LIMB IMPACT LABEL

INDICATION



1

ILLUSTRATIVE DIAGRAM OF RESIDUAL RISKS



2

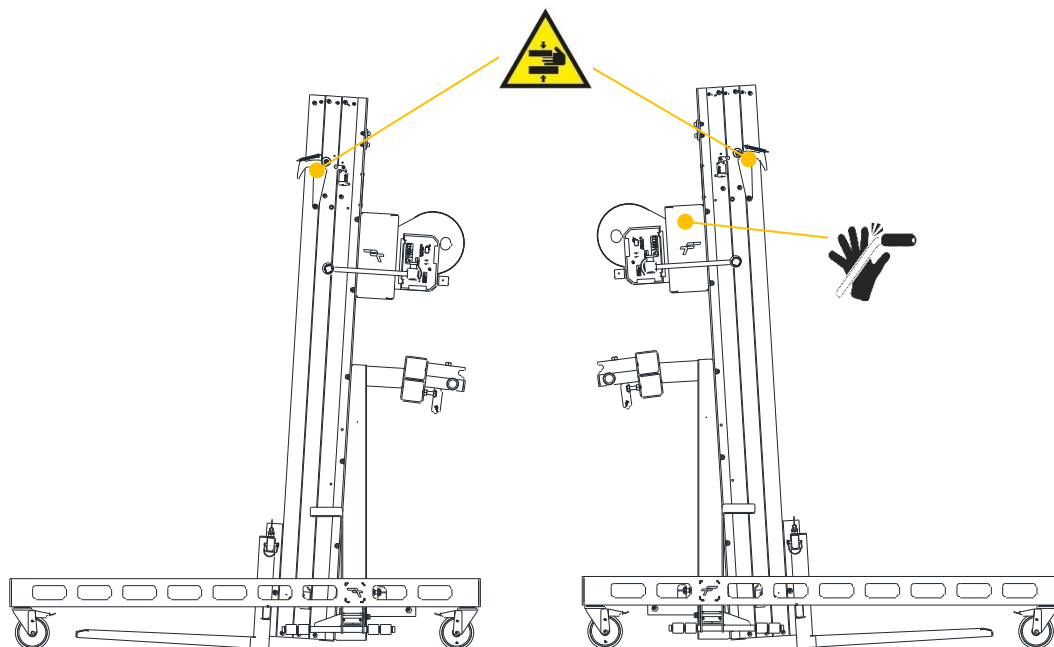
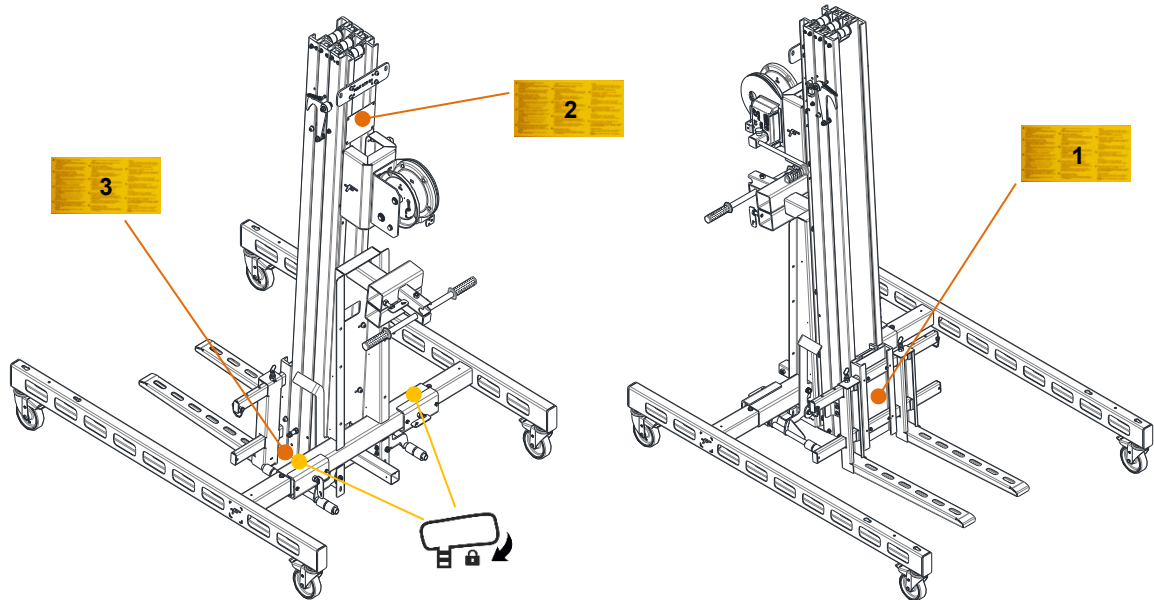
NAMEPLATE APPLICABLE LOADS ON FORKS



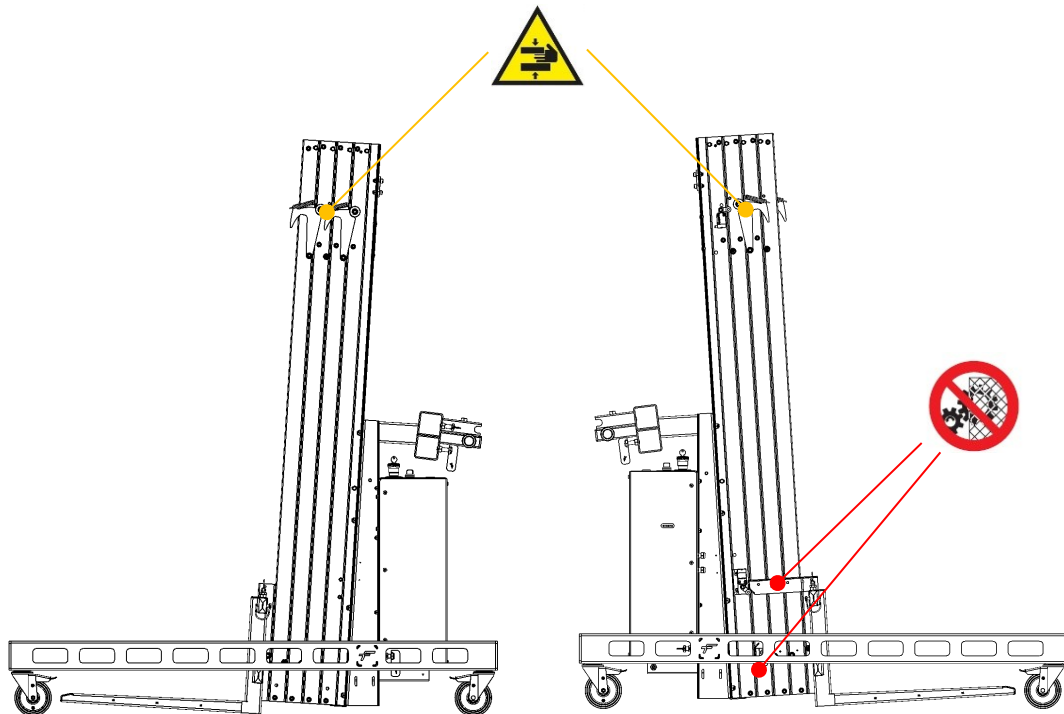
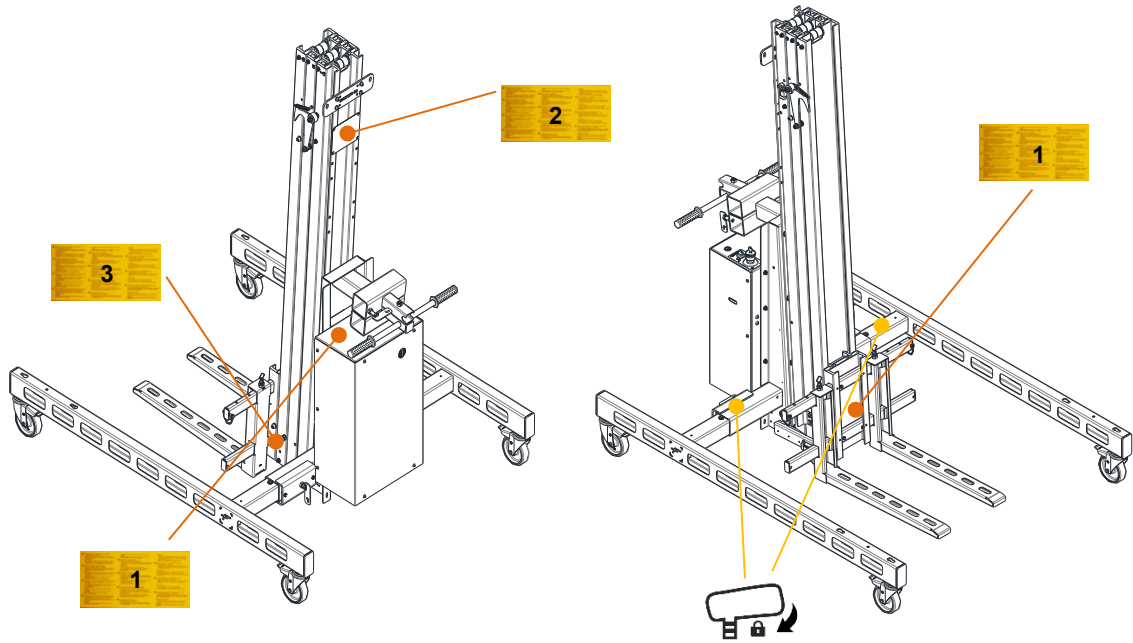
3

FORK LIFTING SLIDE LOCKING SYSTEM

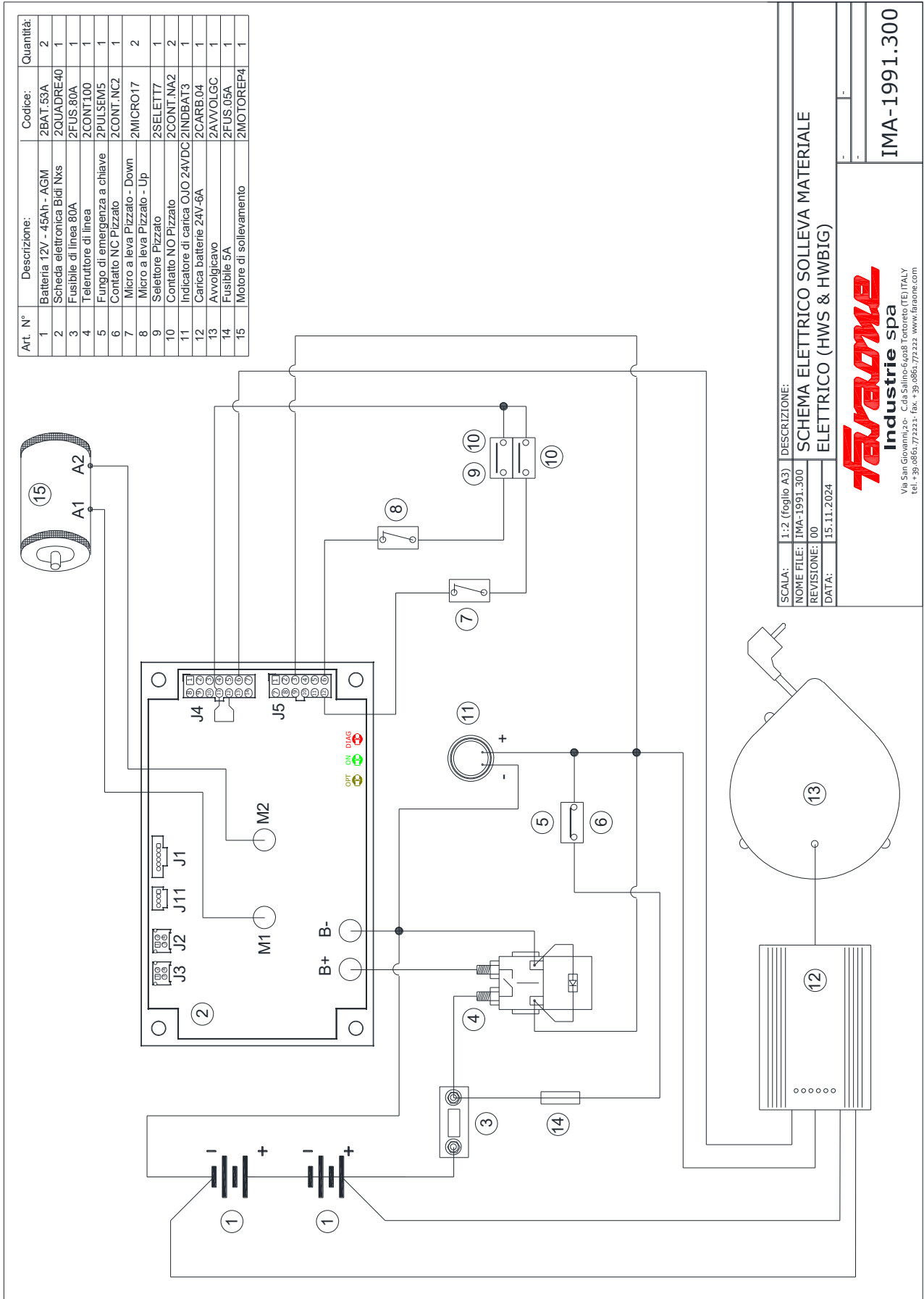
MANUAL VERSION



ELECTRIC VERSION



ANNEX 2 - Circuit diagram (electrical version)



ATTACHMENT 3 – FAC-SIMILE Declaration of conformity

LIFTER HW / HW BIG



FARAONE INDUSTRIE SPA
Via San Giovanni, 20 - C.da Salino
64018 Tortoreto (TE) ITALY
Tel. +39 0861.772221
Fax +39 0861.772222

www.faraone.com
info@faraone.com

REA 92848 CCIAA TE
PIVA e C.F. IT 00732060678
C.S. euro 2.000.000 i.v.



**DICHIARAZIONE DI CONFORMITA' ~ DECLARATION OF CONFORMITY ~
DECLARATION DE CONFORMITE' ~ EG KONFORMITÄTSEKTLÄRUNG ~
DEKLARACJA ZGODNOŚCI ~ DECLARACIÓN DE CONFORMIDAD**

Prodotto / Product / Produit / Produkt / Produkt / Sollevatore Materiali / Material lift / Elévateur de matériaux / Materialheber /
Producto : Podnošnik materiałowy / Elevador de material

Modello / Model / Modèle / Modell / Model / Modelo: _____

Matricola / Serial No. / Numéro sérial / Laufende Nr. /
Nr.seryjny / Numéro de registro: _____

Anno / Year / Année / Jahr / Rok / Año: _____

Il sottoscritto Faraone Pier Giuseppe, in qualità di legale rappresentante della ditta FARAONE INDUSTRIE S.p.A. – C.da Salino, Tortoreto (Italia), Costruttore, nonché persona giuridica autorizzata a costituire il fascicolo tecnico per la macchina in oggetto DICHIARA CHE è stata fabbricata conformemente ai requisiti di sicurezza e salute previsti dalla Direttiva Macchine 2006/42/CE ed alla norma armonizzata EN ISO 3691-5:2020. Il Fascicolo Tecnico di costruzione è conservato presso la FARAONE INDUSTRIE S.p.A. Il Fascicolo Tecnico e la versione originale delle istruzioni di uso e manutenzione vengono redatti in lingua italiana.

The undersigned Faraone Pier Giuseppe, as legal representative of the company FARAONE INDUSTRIE S.p.A. – C.da Salino, Tortoreto (Italy), manufacturer, as well as a legal person authorized to compile the technical file for the machine in question, DECLARES THAT has been manufactured in accordance with the requirements of safety and health of the Machine Directive 2006/42/EC and harmonized standard EN ISO 3691-5:2020. The technical reference of the platform are kept in the records of FARAONE INDUSTRIE S.p.A. The technical file and the original version of the user's manual are written in Italian.

Le soussigné Faraone Pier Giuseppe, agissant en tant que représentant légal de la société FARAONE INDUSTRIE S.p.A. – C. da Salino, Tortoreto (Italie), fabricant, ainsi qu'une personne morale autorisée à constituer le dossier technique de la machine en question DECLARE QUE a été fabriqué en conformité avec les critères de sécurité et de la santé de la Directive Machines 2006/42/CE et la norme harmonisée EN ISO 3691-5:2020. Le dossier technique de construction est entreposé chez FARAONE INDUSTRIE S.p.A. Le dossier technique et la version originale des instructions de fonctionnement et d'entretien sont écrits en italien.

Der unterzeichnete Faraone Pier Giuseppe, als gesetzlicher Vertreter der Firma FARAONE INDUSTRIE S.p.A. – C.da Salino, Tortoreto (Italien), sowie Hersteller und Person die bevollmächtigt ist die technischen Unterlagen für die o.g. Maschine zusammenzustellen, ERKLÄRT dass die nach den Sicherheits- und Gesundheitsanforderungen der Maschinenrichtlinie 2006/42/EG und der harmonisierten Norm EN ISO 3691-5:2020. Die technischen Bauunterlagen werden bei FARAONE INDUSTRIE S.p.A. aufbewahren. Die technischen Unterlagen und die ursprüngliche Version der Bedienungs- und Wartungsanleitungen sind in Italienisch geschrieben.

Niżej podpisany Faraone Pier Giuseppe, jako przedstawiciel prawny firmy FARAONE INDUSTRIE S.p.A. - C. da Salino, Tortoreto (Włochy), Producent, a także osoba prawna upoważniona do sporządzenia dokumentacji technicznej przedmiotowej maszyny OŚWIADCZA, ŻE został wyprodukowany zgodnie z wymogami bezpieczeństwa i ochrony zdrowia przewidzianymi w dyrektywie maszynowej 2006/42/WE oraz normie zharmonizowanej EN ISO 3691-5:2020. Dokumentacja techniczna konstrukcji jest przechowywana w FARAONE INDUSTRIE S.p.A. Dokumentacja techniczna oraz oryginalna wersja instrukcji użytkowania i konserwacji są sporządzone w języku włoskim.

El abajo firmante Faraone Pier Giuseppe, como representante legal de la empresa FARAONE INDUSTRIE S.p.A. – C.da Salino, Tortoreto (Italia), Fabricante, así como persona jurídica autorizada para elaborar el expediente técnico de la máquina en cuestión DECLARA QUE ha sido fabricada respetando los requisitos de seguridad y salud establecidos por la Directiva de Máquinas de 2006 /42/ CE y la norma armonizada EN ISO 3691-5:2020. El Expediente Técnico de Construcción se conserva en FARAONE INDUSTRIE S.p.A. La Ficha Técnica y la versión original de las instrucciones de uso y mantenimiento están redactados en italiano.

Tortoreto, _____

Il Legale Rappresentante
(Faraone Pier Giuseppe)



LIFTER HW EL / HW BIG EL



FARAONE INDUSTRIE SPA
Via San Giovanni, 20 - C.da Salino
64018 Tortoreto (TE) ITALY
Tel. +39 0861.772221
Fax +39 0861.772222

www.faraone.com
info@faraone.com
REA 92848 CCIAA TE
PIVA e C.F. IT 00732060678
C.S. euro 2.000.000 i.v.



**DICHIARAZIONE DI CONFORMITA' ~ DECLARATION OF CONFORMITY ~
DECLARATION DE CONFORMITE' ~ EG KONFORMITÄTSEKTLÄRUNG ~
DEKLARACJA ZGODNOŚCI ~ DECLARACIÓN DE CONFORMIDAD**

Macchina / Machine / Machine / Maschine / Maszyna /
Máquina :

Sollevatore Materiali / Material lift / Elévateur de matériaux / Materialheber
/ Podnośnik materiałowy / Elevador de material

Modello / Model / Modèle / Modell / Model / Modelo: _____

Matricola / Serial No. / Numéro sérial / Laufende Nr. /
Nr.seryjny / Número de registro: _____

Anno / Year / Année / Jahr / Rok / Año: _____

Il sottoscritto Faraone Pier Giuseppe, in qualità di legale rappresentante della ditta FARAONE INDUSTRIE S.p.A. – C.da Salino, Tortoreto (Italia), Costruttore, nonché persona giuridica autorizzata a costituire il fascicolo tecnico per la macchina in oggetto DICHIARA CHE è stata fabbricata conformemente ai requisiti di sicurezza e salute previsti dalla Direttiva Macchine 2006/42/CE, Direttiva EMC 2014/30/UE ed alle norma armonizzata UNI EN 3691-5:2020.

Il Fascicolo Tecnico di costruzione è conservato presso la FARAONE INDUSTRIE S.p.A. Il Fascicolo Tecnico e la versione originale delle istruzioni di uso e manutenzione vengono redatti in lingua italiana.

Le soussigné Faraone Pier Giuseppe, agissant en tant que représentant légal de la société FARAONE INDUSTRIE S.p.A. – C. da Salino, Tortoreto (Italie), fabricant, ainsi qu'une personne morale autorisée à constituer le dossier technique de la machine en question DECLARE QUE a été fabriqué en conformité avec les critères de sécurité et de la santé de la Directive Machines 2006/42/CE, la Directive EMC 2014/30/UE et la norme harmonisée EN 3691-5:2020. Le dossier technique de construction est entreposé chez FARAONE INDUSTRIE S.p.A. Le dossier technique et la version originale des instructions de fonctionnement et d'entretien sont écrits en italien.

Niżej podpisany Faraone Pier Giuseppe, jako przedstawiciel prawny firmy FARAONE INDUSTRIE S.p.A. - C. da Salino, Tortoreto (Włochy), Producent, a także osoba prawna upoważniona do sporządzenia dokumentacji technicznej przedmiotowej maszyny OŚWIADCZA, ŻE został wyprodukowany zgodnie z wymogami bezpieczeństwa i ochrony zdrowia przewidzianymi w dyrektywie maszynowej 2006/42/WE, dyrektywie EMC 2014/30/UE oraz normie zharmonizowanej UNI EN 3691-5:2020. Dokumentacja techniczna konstrukcji jest przechowywana w FARAONE INDUSTRIE S.p.A. Dokumentacja techniczna oraz oryginalna wersja instrukcji użytkownika i konserwacji są sporządzone w języku włoskim.

Tortoreto, _____

The undersigned Faraone Pier Giuseppe, as legal representative of the company FARAONE INDUSTRIE S.p.A. – C.da Salino, Tortoreto (Italy), manufacturer, as well as a legal person authorized to compile the technical file for the machine in question, DECLARES THAT has been manufactured in accordance with the requirements of safety and health of the Machine Directive 2006/42/EC, the Directive EMC 2014/30/EU and harmonized standard EN 3691-5:2020. The technical reference of the platform are kept in the records of FARAONE INDUSTRIE S.p.A. The technical file and the original version of the user's manual are written in Italian.

Der unterzeichnete Faraone Pier Giuseppe, als gesetzlicher Vertreter der Firma FARAONE INDUSTRIE S.p.A. – C.da Salino, Tortoreto (Italien), sowie Hersteller und Person die bevollmächtigt ist die technischen Unterlagen für die o.g. Maschine zusammenzustellen, ERKLÄRT dass die nach den Sicherheits- und Gesundheitsanforderungen der Maschinenrichtlinie 2006/42/EG, der Direktive EMV 2014/30/EU und der harmonisierten Norm EN 3691-5:2020. Die technischen Bauunterlagen werden bei FARAONE INDUSTRIE S.p.A. aufbewahren. Die technischen Unterlagen und die ursprüngliche Version der Bedienungs- und Wartungsanleitungen sind in Italienisch geschrieben.

El abajo firmante Faraone Pier Giuseppe, como representante legal de la empresa FARAONE INDUSTRIE S.p.A. – C.da Salino, Tortoreto (Italia), Fabricante, así como persona jurídica autorizada para elaborar el expediente técnico de la máquina en cuestión DECLARA QUE ha sido fabricada respetando los requisitos de seguridad y salud establecidos por la Directiva de Máquinas de 2006 /42/ CE, Directiva EMC 2014/30/UE y la norma armonizada UNI EN 3691-5:2020. El Expediente Técnico de Construcción se conserva en FARAONE INDUSTRIE S.p.A. La Ficha Técnica y la versión original de las instrucciones de uso y mantenimiento están redactados en italiano.

Il Legale Rappresentante
(Faraone Pier Giuseppe)

FARAONE
Industrie spa
C.da Salino - Via San Giovanni, 20
64018 TORTORETO (Te) - Tel. 0861.77221
Fax 0861.772222 - P. IVA 00732060678



Faraone Industrie Spa
Contrada Salino – Via San Giovanni, 20
64018, Tortoreto (TE) – ITALY
Tel.: +39.0861.77.22.21 – fax: +39.0861.77.22.22
www.faraone.com
info@faraone.com